

| REV | DATE | DESCRIPTION | ECO | SIGN |
|-----|---------|------------------|-----|------|
| 1 | 5/15/02 | RELEASE TO PILOT | | |
| 2 | 6/15/07 | WAS 1.000 TALL | | |

SPECIFICATIONS:

| | |
|---|---|
| RATED CAPACITY, FATIGUE RATED FOR INFINITE LIFE | 30,000 POUNDS |
| RATED OUTPUT | 3 mV/V typical |
| COMBINED ERROR | ± 0.25 % |
| NON-REPEATABILITY | < 0.05 % |
| ZERO BALANCE | ± 10 % |
| TEMPERATURE RANGE, COMPENSATED | -65 TO 200ø F |
| TEMPERATURE EFFECT, OUTPUT | 0.005 % of Load / ø F |
| TEMPERATURE EFFECT, ZERO BALANCE | Not rated |
| INPUT IMPEDANCE | 350 OHMS, typical |
| OUTPUT IMPEDANCE | 350 OHMS, typical |
| EXCITATION VOLTAGE (typical) | 10 VDC or VAC rms |
| EXCITATION VOLTAGE, MAXIMUM | 15 VDC or VAC rms |
| INSULATION RESISTANCE | 5,000 MEG OHMS @ 50 VDC |
| MAXIMUM LOAD, SAFE | 125 % F.S. |
| MAXIMUM LOAD, ULTIMATE | 200 % F.S. |
| DEFLECTION AT RATED CAPACITY, APPROXIMATE | 0.002 in. |
| ENVIROMENTALLY SEALED WITH "O" RINGS AT EACH CONTACT POINT. | |
| CONSTRUCTION | TOOL STEEL ELEMENT, STAINLESS STEEL COVER |

(3) 9/32 CTR. BORE X 0.340 DP.
EQ. SPACED ON A
Ø1.625 BOLT CIRCLE
CELL WORKS BEST WHEN MOUNTED
WITH (3) #6-32 X0.75 LONG S.H.C.S.

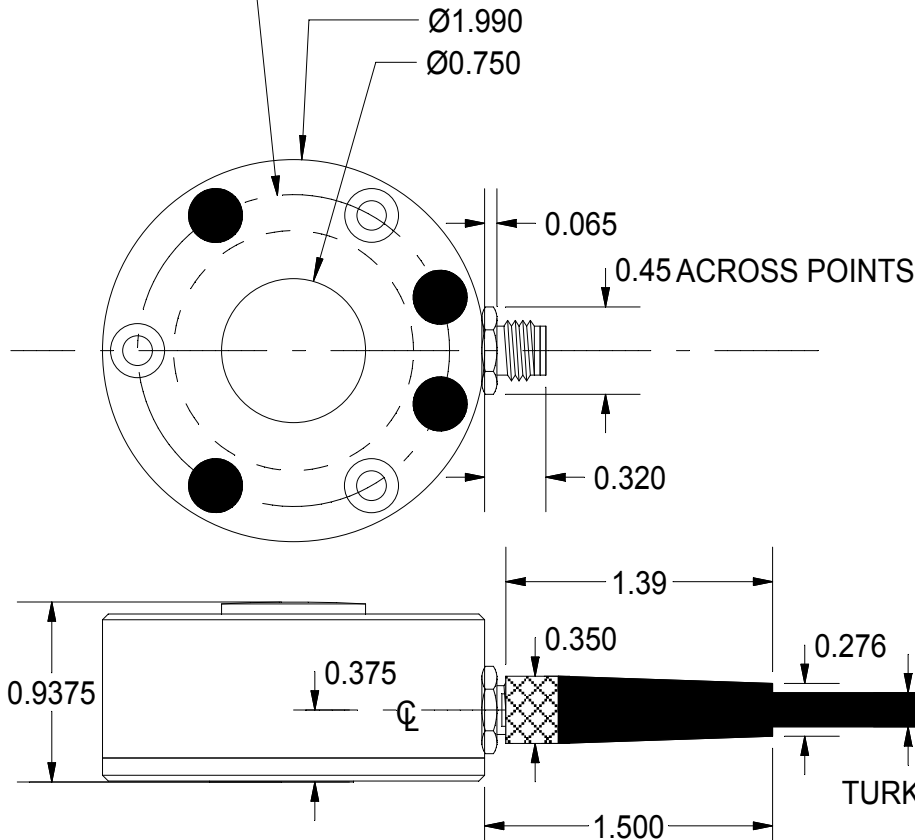

TURCK 4 PIN PICO
MALE RECEPTACLE
REAR

| | | | |
|--------------|---|---|--------------|
| BROWN + EXC. | 1 | 3 | BLUE - SIG. |
| WHITE - SIG. | 2 | 4 | BLACK - EXC. |

| WIRE COLOR CODE: | | PIN NO. |
|------------------|-------|---------|
| +EXCITATION | BROWN | 1 |
| +SIGNAL | WHITE | 2 |
| - SIG | BLUE | 3 |
| - EXCITATION | BLACK | 4 |

TURK (PKG 4M-2/S90/S618) OR EQUIVALENT

RECOMMENDED MOUNTING SCREW IS A #6-32 X 3/4" LONG SOCKET HEAD CAP SCREW, (3) REQUIRED.

TOLERANCES UNLESS OTHERWISE SPECIFIED:
.XXX = ± 0.005
.XX = ± 0.015
.X = ± 0.025

SCALE: FULL



Designed By: **Mettert**

Drawn By:

Approved By:

Date: **5/15/02**

Date:

Date:

Title / Description:
**SS1406-30K BUTTON
LOAD CELL
SPECIFICATIONS**

Dwg. Size:
A

Dwg. Type:
SPEC

Page 1 of 1

Part No. **SS1406-30K**

File Name
13540SP.FCD

Doc. No.
13540