

REV	DATE	DESCRIPTION	ECO	SIGN
1	02/02/98	RELEASE TO PILOT	602	RAB

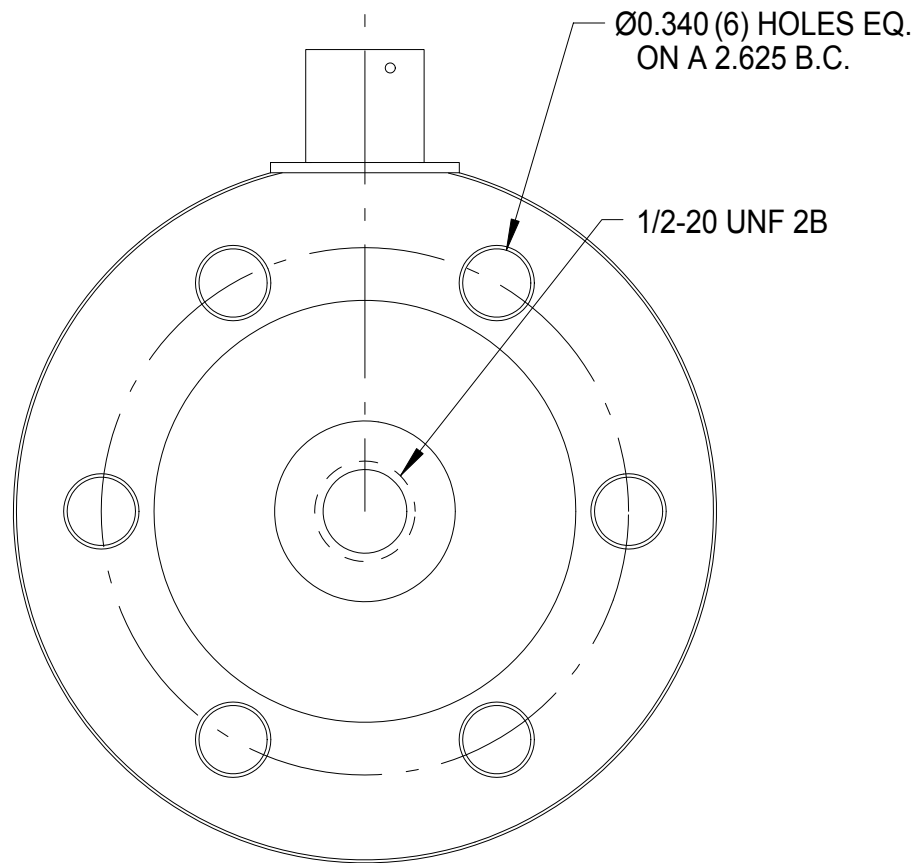
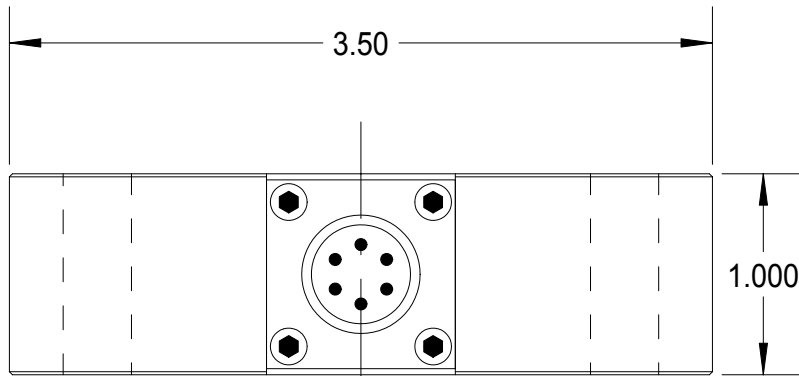

SPECIFICATIONS:

RATED CAPACITY	5K POUNDS
RATED OUTPUT	2.5 mV/V typical
COMBINED ERROR	±0.05% / CURVE PROVIDED
NON-REPEATABILITY	0.01 %
ZERO BALANCE	± 10 %
TEMPERATURE RANGE, COMPENSATED	+60 TO 160° F
TEMPERATURE EFFECT, OUTPUT	0.0015 % of Load / ° F
TEMPERATURE EFFECT, ZERO BALANCE	0.0015 % of Load / ° F
INPUT IMPEDANCE, OUTPUT IMPEDANCE	700 OHMS, typical
EXCITATION VOLTAGE (typical)	10 VDC or VAC rms
EXCITATION VOLTAGE, MAXIMUM	15 VDC or VAC rms
INSULATION RESISTANCE	5,000 MEG OHMS @ 50 VDC
MAXIMUM LOAD, SAFE	125 % F.S.
MAXIMUM LOAD, ULTIMATE	200 % F.S.
DEFLECTION AT RATED CAPACITY, APPROXIMATE	0.005 in.
CONSTRUCTION	ALLOY STEEL
RECEPTACLE ON LOAD CELL	PT02E-10-6P

PIN COLOR DESIGNATION

A&B	GREEN	+ EXC.
C&D	BLACK	- EXC.
E	RED	- SIG.
F	WHITE	+ SIG.

SHLD. FLOATS > 5KM OHMS TO GROUND

TOLERANCES UNLESS OTHERWISE SPECIFIED:

.XXX = ± 0.005

.XX = ± 0.015

.X = ± 0.025

SCALE: FULL



TOLEDO
TRANSDUCERS,
INC.

Designed By: **Mettert**

Date: **1/9/98**

Title / Description:
5K LBS LOAD CELL 3 mV/V
SS1176-5K SPECIFICATIONS

Part No. **SS1176-5K**

Drawn By:

Date:

File Name **10501SP.FCD**

Approved By:

Date:

Dwg. Size: **A**
Dwg. Type: **SPEC**

Page 1 of 1

Doc. No. **10501**