

REV	DATE	DESCRIPTION	ECO	SIGN
1	11/21/96	RELEASE FOR QUOTING PURPOSES	437	RAB
		RELEASE TO PILOT		

WIRE COLOR CODE:

+ EXCITATION YELLOW
- EXCITATION BLACK
+ SIGNAL WHITE
- SIGNAL RED
SHIELD 1 OHM TO ELEMENT*

*(DYNAMIC LOAD CELL USED WITH T.T.I. PRODUCTION / LOAD MONITOR.)

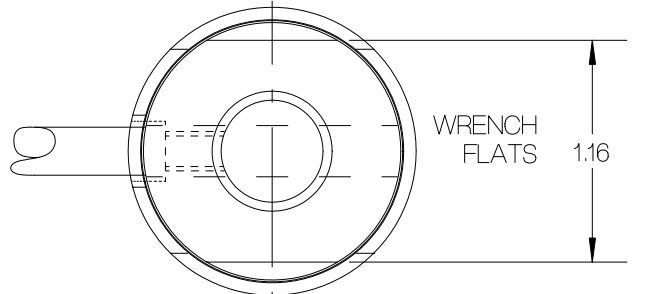

INSTALLATION TORQUE SHOULD NOT EXCEED 1,050 IN-LB ON THIS END OF LOAD CELL

5 FEET STAINLESS STEEL METAL FLEX. HOSE
6 FEET OF TEFLON SENSOR CABLE.

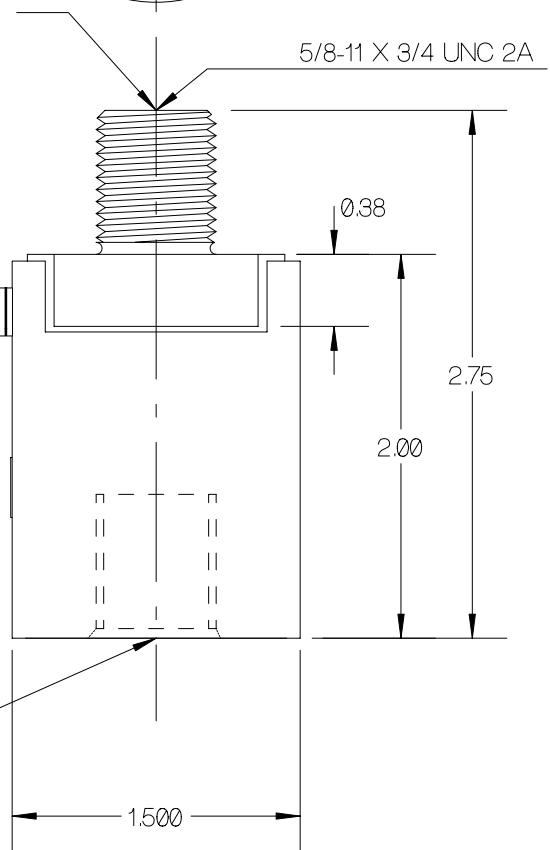

SPECIFICATIONS:

RATED CAPACITY	20,000 POUNDS
RATED OUTPUT	2 mV/V typical
COMBINED ERROR	0.25 %
NON-REPEATABILITY	0.05 %
ZERO BALANCE	± 1 %
TEMPERATURE RANGE, COMPENSATED	+14 TO 104° F
TEMPERATURE EFFECT, OUTPUT	0.014 % / ° F
TEMPERATURE EFFECT, ZERO BALANCE	0.05 % / ° F
INPUT IMPEDANCE	350 OHMS, typical
EXCITATION VOLTAGE (typical)	10 VDC or VAC rms
EXCITATION VOLTAGE, MAXIMUM	15 VDC or VAC rms
INSULATION RESISTANCE	5,000 MEG OHMS @ 50 VDC
MAXIMUM LOAD, SAFE	150 % F.S.
MAXIMUM LOAD, ULTIMATE	300 % F.S.

TOLERANCES UNLESS OTHERWISE SPECIFIED:	
.XXX = ± 0.005	SCALE: FULL
.XX = ± 0.015	
.X = ± 0.025	
FINISH: FINE BRUSHED FINISH, O.D. NO MARKS	
MAT'L: ALLOY STEEL / STAINLESS STEEL	



Designed By: **Mettert**
Drawn By:
Approved By:

Date: **11/15/96**
Date:
Date:

Title / Description:
INSERTION LOAD CELL SPECIFICATIONS

Dwg. Size: **A** Dwg. Type: **SPEC**

Page 1 of 1

Part No. **SS1122-20K**
File Name **10160SP.FCD**
Doc. No. **10160**