

**TTLM I/O**  
**Installation, Calibration &**  
**Operator's Manual**

---

Revision E, Oct. 2009

# TTLM

## Table of Contents

---

- Limited Warranty ..... 2
- Features Overview..... 3
- Specifications ..... 4
- Mounting the TTLM ..... 5
- Connecting Sensors to the TTLM ..... 6
- Supplying AC Power to the TTLM..... 8
- Supplying DC Power to the TTLM..... 9
- TTLM Cam Switch Wiring Connections ..... 10
- Wiring a Triggering Device Into the TTLM ..... 11
- The Analog Output Connector ..... 12
- Calibrating the TTLM ..... 13
- Setup the TTLM with Pre-calibrated Load Cells ..... 16
- Operating the TTLM ..... 17
- Definition of Terms ..... 18

## Table of Figures

---

- 1 Mounting Hole Arrangement ..... 5
- 2 Strip the Cable Panel ..... 6
- 2a Cable through the Lug ..... 6
- 2b Side View ..... 6
- 2c Color Codes ..... 6
- 3 Channel Connections..... 7
- 4a A.C. Power Connections ..... 8
- 4b D.C. Power Connections ..... 9
- 5 Probe Interface Connections ..... 10
- 6 Probe Timing..... 11
- 7 Analog Output Connections ..... 12
- 8 Calibration Controls ..... 13-17

## Appendix

---

- A Sensor Placement & Installation ..... 20
- B Replacing a T400 Sensor ..... 28

# TTLM

## Limited Warranty

---

This unit is warranted by the manufacturer, Toledo Transducers, Inc., to be free of defects in workmanship and materials for one year from date of manufacturer's shipment. This warranty is limited to repairing or replacing products which manufacturer's investigation shows were defective at the time of shipment by the manufacturer.

All products subject to this warranty must be returned for examination, repair or replacement

F.O.B. to: Toledo Transducers, Inc.  
6834 Spring Valley Drive  
Holland, Ohio 43528

***The express warranty set forth herein is in lieu of all other warranties, expressed or implied, including without limitation any warranties of merchant-ability or fitness for a particular purpose. All such warranties are hereby disclaimed and excluded by the manufacturer.***

Repair or replacement of defective products as provided above is the sole and exclusive remedy provided thereunder. The manufacturer shall not be liable for any further loss, damages, or expenses, including incidental or consequential damages, directly or indirectly arising from the sale or use of this product.

Any unauthorized repair voids this warranty.

There are no warranties that extend beyond those expressly set forth herein.



## Features Overview

- Signal conditioning module for strain gage sensors and load cells
- Four independent channels for accommodating up to eight sensors
- For use with full bridge sensors from 120 Ohms to 1,000 Ohms
- Plug-in connectors are used for sensor inputs
- High/low sensitivity span ranges selected with front panel switch
- Automatic zero balance circuits assure accurate measurements
- Power input/output are plug-in connectors
- Built-in automatic peak load memory circuits
- Peak measurements are made with an external trigger device
- Built-in power supply for stable operation and noise rejection
- Compact size to fit almost any location
- Steel enclosure for maximum protection and noise rejection

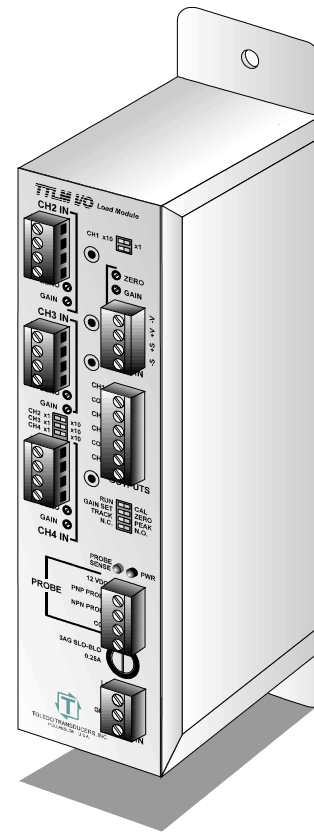

*TTLM I/O Load Module.*

The new TTLM I/O Load Module has been designed with user friendliness in mind. The unit incorporates the use of Phoenix Connectors on the sensor inputs as well as the analog output for easier wire installation. The TTLM was designed to condition the output from most 350 Ohm bridge sensors such as Toledo Transducers, Inc. T400 Load Sensors or load cells. It provides an analog output in the range of +/-9 VDC for use by many standard A/D conversion products. Several useful functions such as auto-zeroing and peak hold circuits have been incorporated to make the TTLM a versatile signal conditioner.

**Note: The TTLM is a signal conditioner which can be used as an input to a PLC or a PC with the appropriate software to convert the TTLM's analog signal into a useable digital tonnage reading. The software should also have a routine that allows for tonnage calibration in order to achieve accurate readings. If you have questions concerning the software or hardware needed to convert the analog signal to a tonnage reading contact:**

**Toledo Transducers, Inc.  
6834 Spring Valley Drive  
Holland, Ohio 43528  
Phone: 419-867-4170**



## Specifications

Transducers	Full Bridge, 120 OHMS to 1000 OHMS. One to Four channel version available. Maximum of two 350 Ohm sensors, paralleled connection, per channel.
Dimensions	2.00" x 3.10" x 8.95"
Balance Range	+/- 1mV/V of offset
Gain - Two Ranges	Low gain = 100 to 1,100 adjustable High gain = 1000 to 11,000 adjustable
Output Range	+/-9 VDC @ 12 VDC excitation
Circuit Accuracy	Maximum inaccuracy of +/- 1% of full scale
Circuit Linearity	Maximum non-linearity +/- 0.1% of full scale
Auto Zero Time Constant	10 Seconds
Frequency Response	Flat DC to 1 KHz.
Peak Decay	Less than 1% of full scale in 10 minutes
Calibration Shunts	1 Meg OHM, 0.1%
Input Power	90 to 240 VAC 50-60 Hz. <i>DC option: 24 VDC</i> Fused at 0.25 Amp      Type: 3AG SLO-BLO
Sensor Excitation	Internally excited at +12 VDC, .30 Amps maximum
Sensor Input Connections	Four pin 5.08 mm centers (.2") Phoenix connector
Peak Output Connections	Six pin 5.08 mm centers (.2") Phoenix connector
Proximity Probe	12 VDC internally supplied to drive NPN or PNP probes, 50mA max. Input also supports dry relay contacts.



### Mounting the TTLM

The dimensions and the recommended mounting hole arrangement for the TTLM. Use #10 screws to securely mount the TTLM in an enclosure suited to the environment.

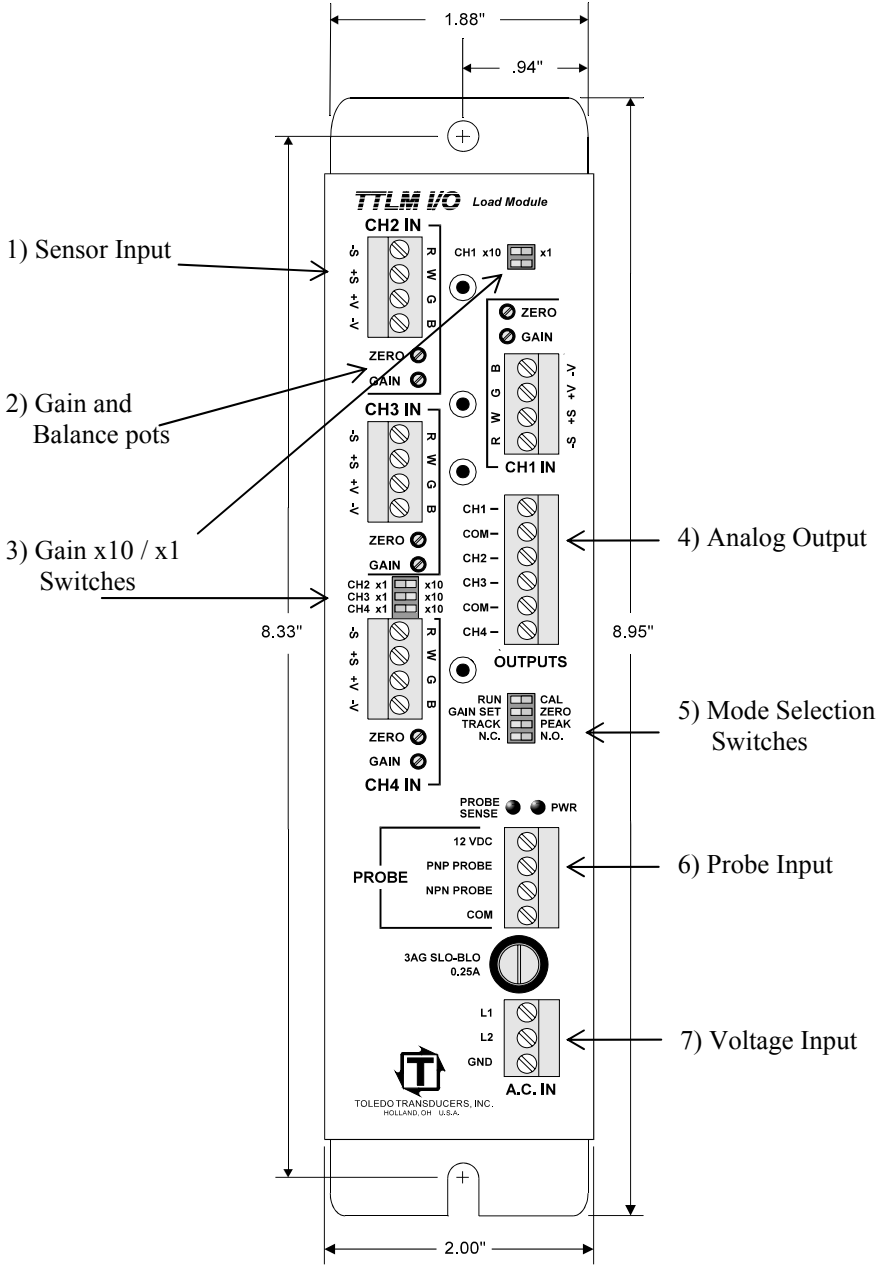

Figure 1

# Connecting Sensors to the TTLM

(See appendix A for sensor placement & installation)

## Sensor Connection Guidelines

- 1). Strip the sensor cable as shown in Figure 2.  
Be sure not to nick any of the signal conductors or strip the shield completely away. At least 1/2 inch of cable shield should be exposed for proper insertion in to the wire lug.

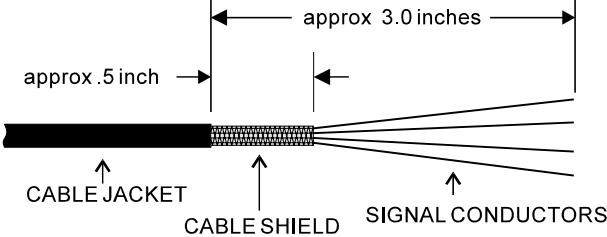

Figure 2

- 2). Insert the cable through the lug as shown in Figure 2a.  
Make sure the cable shield is aligned with the portion of the wire lug which will be crimped.
- 3). Next, crimp the lug on to the cable shield, **do not crimp too tight and risk smashing the wires**. This could cause them to short to ground. Figure 2b shows a side view of the completed operation after crimping.

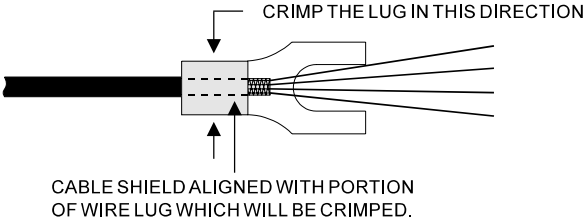

Figure 2a

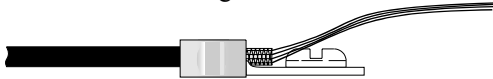

Figure 2b

- 4). Attach the wire lug to a ground terminal on the front of the TTLM. Use a 6-32 x 1/4' screw for the grounding lug connection. If you have a Toledo Transducers sensor, attach the signal wires to the channel connector following the color codes in Figure 2c.

Note: If your sensor is not double shielded with both foil and a braid, electrical noise may affect your output readings.

Note: Some brands of sensors use a different color code than the red/white/green/black colors. It is important to check the spec sheet of the sensor. The spec sheet will indicate the excitation and signal.

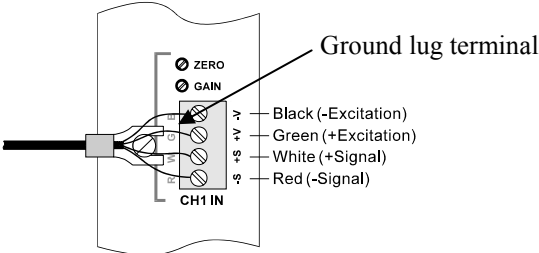

Figure 2c

**Connecting Sensors to the TTLM**

The TTLM Load Module accepts the signals from Toledo Transducers T400 sensors as well as other strain gages. Figure 3 illustrates the sensor connections available on the TTLM

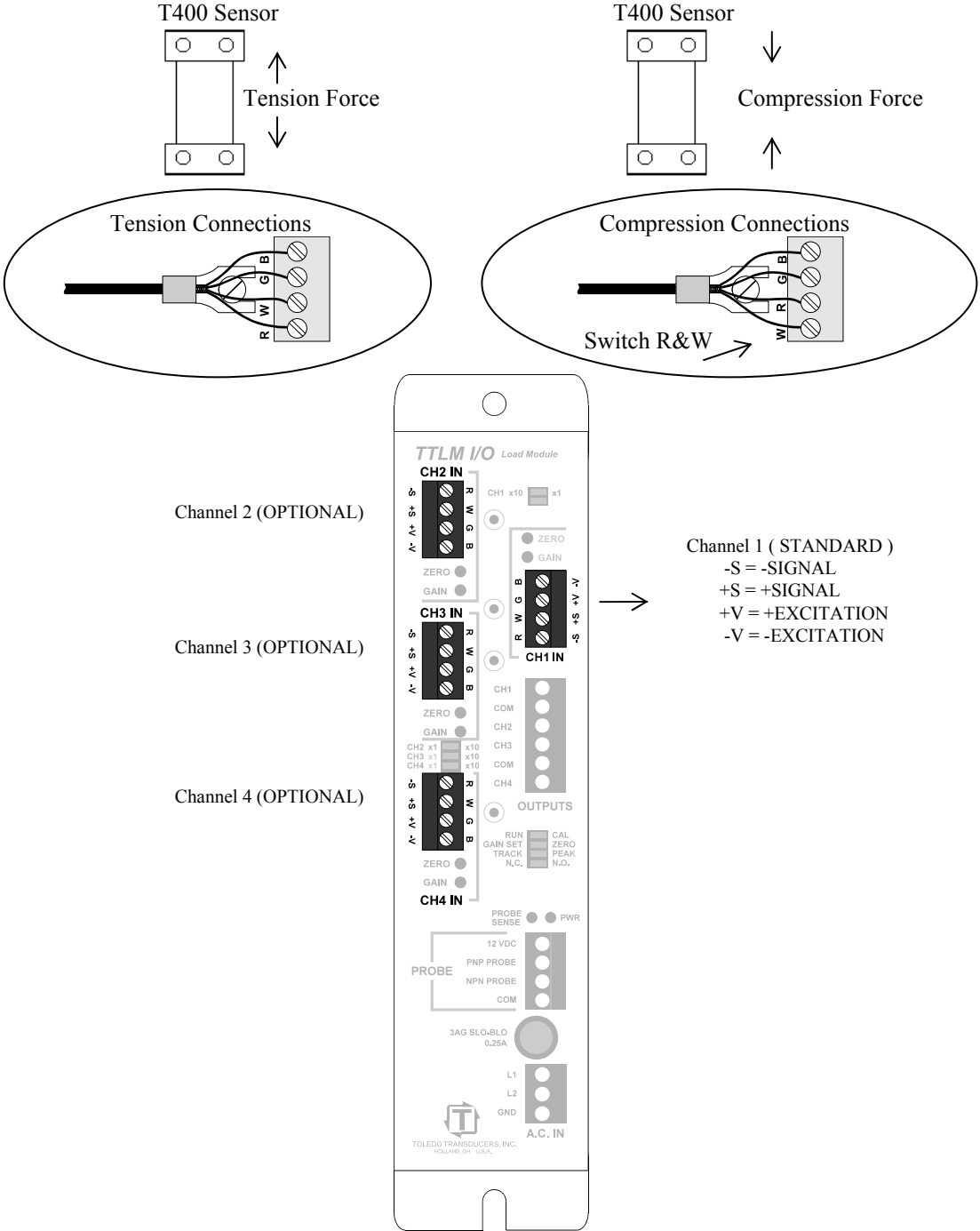

Figure 3 - TTLM Channel Connections (2 through 4 are optional).

**Supplying AC power to the TTLM**

*Note: If TTLM has DC option see next page.*

- The TTLM can use an input range of 90-240 VAC.
- Input power is connected by means of the front panel “A.C. IN” connector and fused with a 250mA slo-blo fuse.

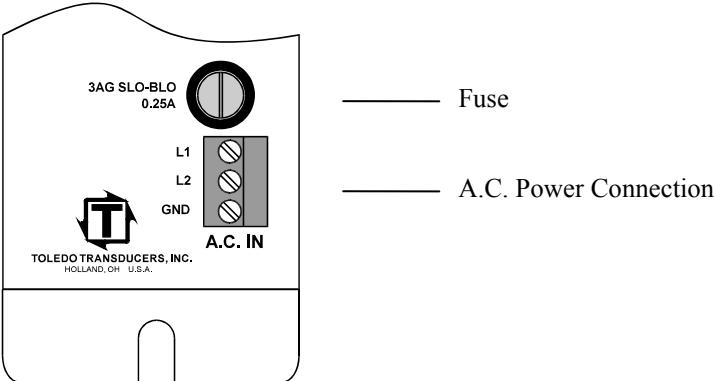

Figure 4a - Front Panel A.C. Power Connections.

**Supplying DC power to the TTLM (DC option only)**

- The DC TTLM uses an input of 24VDC.
- Input power is connected by means of the front panel “D.C. IN” connector and fused with a 250mA slo-blo fuse.

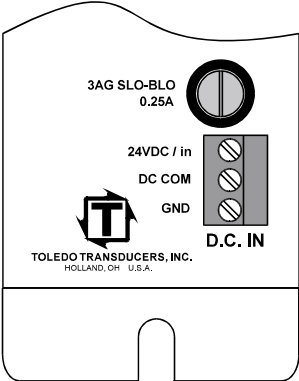

Figure 4b - Front Panel D.C. Power Connections.

# TTLM Cam Switch Wiring Connections

- The probe supply voltage is provided by the TTLM via the +12VDC output connection on the PROBE interface connector. (This is different from first generation module which required an external supply.)
- The diagram below illustrates the wiring for both the PNP and NPN probe types.
- Either a normally open or normally closed probe may be used.
- The LED directly above the probe input connector (PROBE SENSE) indicates the actual state of the probe.
- This LED should turn on at 140° and turn off at 240°. If it is working just the opposite, simply flip the N.C. -N.O. Dip Switch to invert the logic of the probe signal in the TTLM.

## TTLM Probe Interface Connections

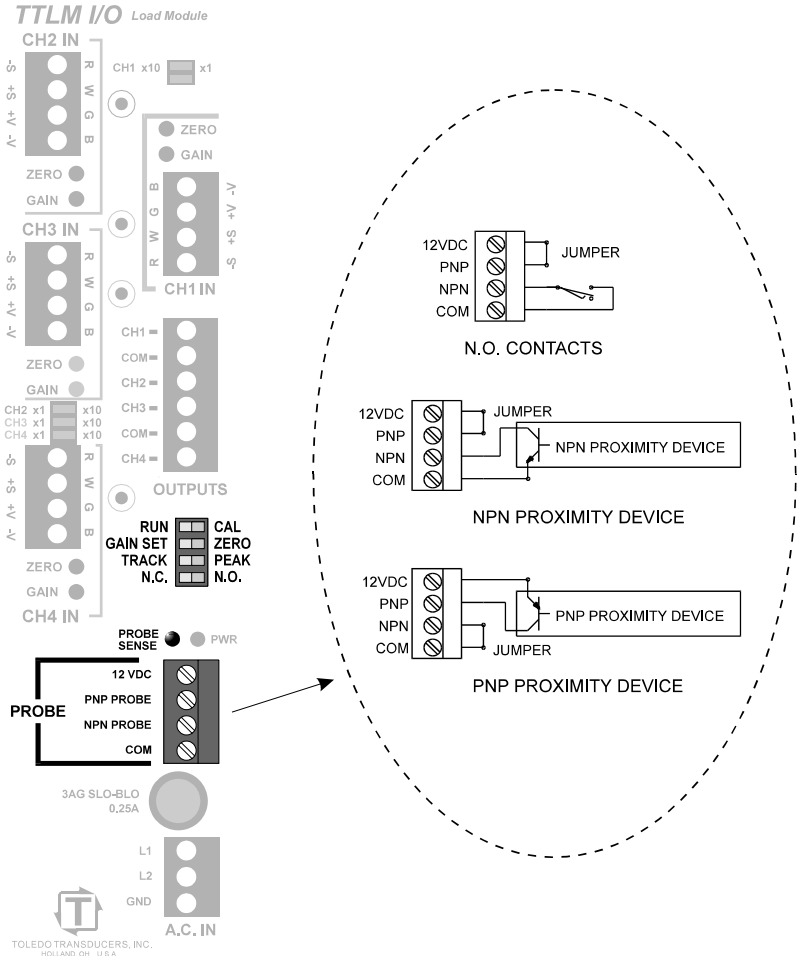

Figure 5

## Wiring a Triggering Device Into the TTLM

The TTLM remains in the auto-zeroing mode of operation until an external probe is applied.

The auto zero feature is important for accurate readings. Over time the press frame will slightly change in its structure. This may be due to temperature or press frame tension. The TTLM will compensate for the slight change. It will readjust the zero base line. This zero base line is the no-load value of the press. With a consistent zero value, the tonnage output readings should remain accurate.

When the probe turns on, the TTLM opens the window to read a load signal. In peak mode the load level rises to the highest value.

When the probe turns off, the peak level is reset and the auto-zeroing function is resumed. (Notice the dotted line below).

The timing of the probe should be such that it turns on just before the machine begins generating a load (140°) and remains on until the load is removed (240°) and the TTLM outputs have been read.

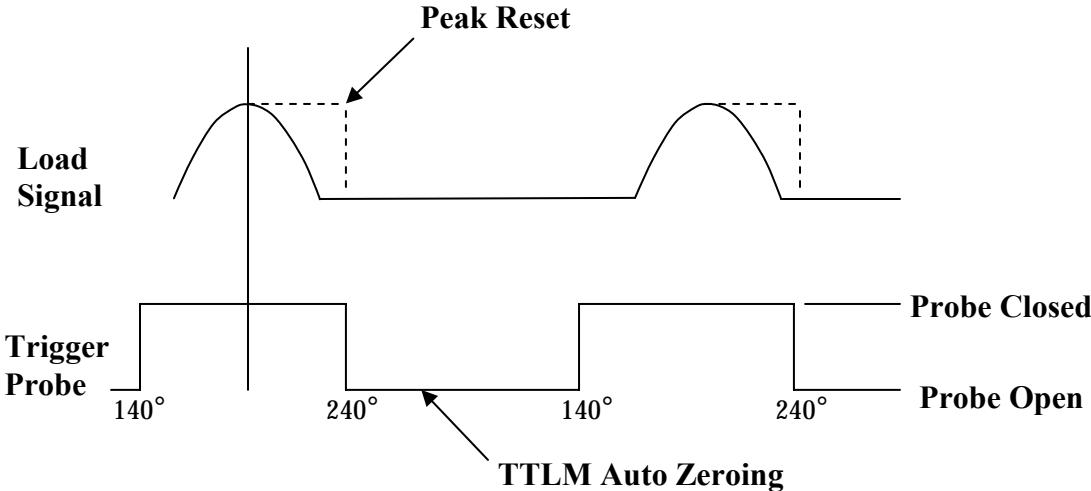
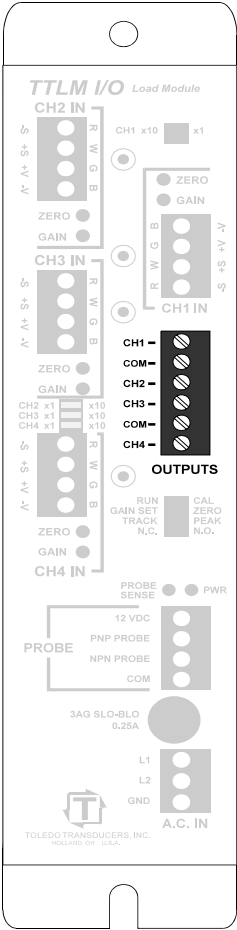

Figure 6  
The recommended timing of the probe vs. the loading on the machine.

# The Analog Output Connector

The analog outputs are provided on a 6 pin Phoenix connector for easy access. The voltage level at these outputs ranges from 0 V at no load, up to +/-9 V at maximum.

This output voltage level is directly related to the gain setting of each channel.



Analog Voltage Output Connector  
 Pin 1 = Ch 1 out  
 Pin 2 = Common  
 Pin 3 = Ch 2 out  
 Pin 4 = Ch 3 out  
 Pin 5 = Common  
 Pin 6 = Ch 4 out

Figure 7 The analog output connections provided for interfacing to other peripherals.

## Calibrating the TTLM Load Module

*\*If you have a Maximizer Load Monitor (Allen Bradley based system), please refer to that manual for proper calibration of the TTLM.*

Figure 8 highlights the switches and controls used to calibrate the TTLM Load Module.

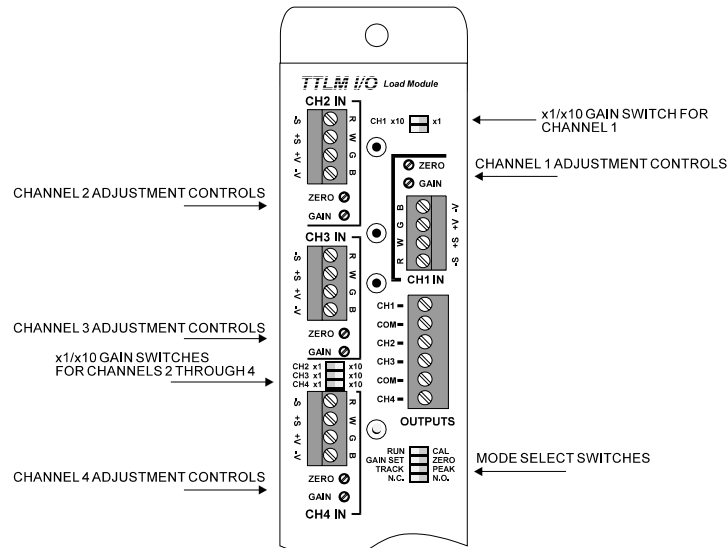
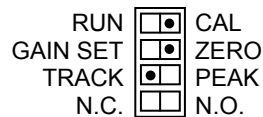

Figure 8

- Step 1) With the sensors placed in the best possible location, (see appendix A), torque all of the sensors down to 150 in/lbs on the sensor bolts. Do not put the sensor enclosure covers on yet. You will need to test each sensor location.
- Step 2) Toggle the mode select switches to CAL, ZERO, TRACK:



- Step 3) On your output plug, connect your volt meter to channel one and common. Now adjust the zero pot so your voltage is adjusted to 0.00 VDC. After completing channel one, do the same for the rest of the channels.
- Step 4) Again connect your volt meter to the output plug on channel one and common. Have someone put pressure on channel one's sensor with their thumb. It should slightly change as pressure is applied. This will verify your sensor location. Normally we locate our sensors:

- Ch1 = Left Rear
- Ch2 = Right Rear
- Ch3 = Left Front
- Ch4 = Right Front

- Step 5) Coat the sensors with silicone if you are calibrating a forging press. This will help prevent water and carbon contamination that might damage the sensors over time. Put covers on all sensor enclosures.
- Step 6) Without load cells in the press, cycle the press and stop it at bottom dead center. Measure between the ram and the bed to determine the size of the spacers you will need. Be careful to allow around a 1/8 in. gap between the ram and the load cells.  
*\* Damage to the press could occur if the ram locks up the load cells due to an improper measurement.*
- Step 7) Cycle the press so the ram goes to the top. Insert the load cells and spacers. Keep the load cells symmetrical with each other in the bed of the press. Record their placement on a calibration sheet.
- Step 8) Cycle the press over and over. Each time lower the adjustment until you reach the tonnage rating of the press.  
*\* The load will increase approximately 1 ton for every 1/1000 inch as you begin to lower the adjustment.*
- Step 9) Make sure to evenly distribute the load on all load cells using shims if needed. You are now ready to adjust the gain of the TTLM.

**Note: If your PLC does not have the ability to digitally adjust tonnage values proceed to Step 13.**

- Step 10) For PLC readout devices that have tonnage adjustment capabilities, set the mode select switches to CAL, GAIN SET, TRACK:

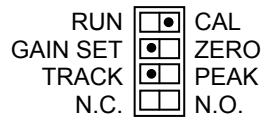

- Step 11) Adjust each channel's gain pot to 2.5 VDC. (Some systems may use a slightly higher voltage level)
- Step 12) Toggle the switches to RUN, ZERO, PEAK and adjust the PLC's tonnage readings to equal those of the load cells. Proceed to Step 15.

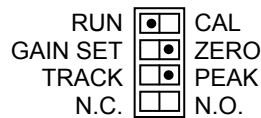

- Step 13) For PLC's that do not have the ability to digitally adjust tonnage, you must manually adjust the gain of the TTLM.

Note: Make sure your analog card input has a rating of 0 to 5VDC for each channel's input.

Set the mode switches to select RUN, ZERO, PEAK:

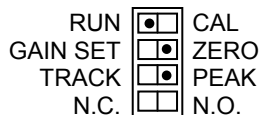

Step 14) Adjust the gain pot after each press cycle until the readings on your PLC display match the readings of the load cells. To obtain more gain set the x10 switch to x10.

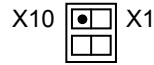

Step 15) After the TTLM is calibrated to match the load cells at press capacity, record on your Cal sheet the tonnage value of each TTLM channel and of each load cell.

Now check press linearity at lower tonnage by collecting tonnage data at 75%, 50% and 25% of press capacity. Do this by increasing the slide adjust or by removing shim material from the load cells. Do not adjust PLC tonnage or TTLM gain in order to match the load cell tonnage at these points, this is for documentation purposes only. Record all tonnage values on your Cal sheet.

Step 16) Record the Calibration Numbers.

- A) If you programmed the tonnage values with your PLC obtain the calibration numbers (sometimes referred to as points) from your PLC and record them on your Cal sheet. You are now finished.
- B) If you manually adjusted the gain of the TTLM to obtain correct tonnage readings, toggle the mode switch to select CAL, ZERO, TRACK and rebalance each sensor to 0VDC (refer to Steps 2 and 3).

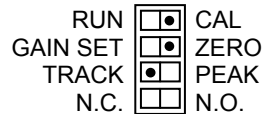

Set the mode switch to CAL, GAIN SET, TRACK and measure the voltage of each channel. These voltages will be your calibration numbers that need to be recorded on your Cal sheet.

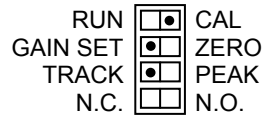

- C) **Important; Make sure the mode switch is returned to RUN, ZERO, PEAK before putting the press back in service.**

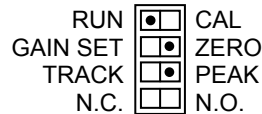

*\* To see a track output on your scope, you must put the unit into TRACK mode. When in TRACK mode, most PLC units will not record correct tonnage values.*

## Setup the TTLM with Pre-calibrated Load Cells

Step 1) Locate the following information from the **load cell calibration data sheet**:

**Cal. No. mV/V** \_\_\_\_\_  
**Shunt Resistance** \_\_\_\_\_  
**Output at Rated Capacity** \_\_\_\_\_

Step 2) Calculate the **Adjusted (Cal. No. mV/V)** for the standard TTLM with a 1Meg shunt resistor by completing the following formula. Do this step only if the **Shunt Resistor** on your **load cell calibration data sheet** is different from the shunt resistor inside the TTLM, otherwise skip to step number 4. *(The TTLM shunt resistor value is printed on the identification label and is part of the model number, i.e. TTLM-4-1M. The 1M means 1,000,000 ohms)*

$$(.000001) \times (\text{Shunt Resistance}) \times (\text{Cal No. mV/V}) = \text{Adjusted (Cal. No. mV/V)}$$

Step 3) Determine the **Full Scale Output** for the TTLM. Suggested voltage is as follows: 5VDC **Full Scale Output** when the pressing machine produces 100% of Rated Capacity on the load cell. Other less common Full Scale Output voltage is 2.5 VDC when the pressing machine produces 100% of Rated Capacity on the load cell.

Step 4) Calculate the **Cal. No. Voltage** setting. This number represents the gain factor of the internal TTLM amplifiers.

$$\text{Full Scale Output} \times \text{Adjusted (Cal. No. mV/V)} / \text{Output at Rated Capacity} = \text{Cal. No. Voltage}$$

Example #1 for a 350 ohm bridge load cell: 5VDC x 0.08848 mV/V / 1.05623 mV/V = 0.4188 VDC  
 Example #2 for a 700 ohm bridge load cell: 5VDC x 0.17696 mV/V / 1.05623 mV/V = 0.8377 VDC

Step 5) Switch the TTLM to CAL, ZERO, TRACK;

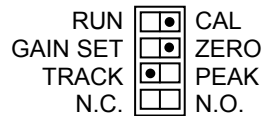

Adjust each balance pot to so that each channel output will read 0.000 VDC.

Step 6) Switch the TTLM to CAL, GAIN SET, TRACK;

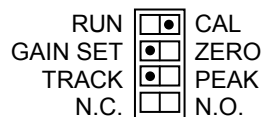

Adjust the gain pot until the channel Output Voltage is equal to the **Cal. No. Voltage** from Step 4. Repeat steps 5 and 6 at least two times.

Step 7) Switch the TTLM back to RUN, ZERO, PEAK;

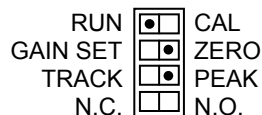

# Operating the TTLM

Once the TTLM has been calibrated it is ready for continuous use. To ready the TTLM for load conversions, follow these four steps: ( Figure 8)

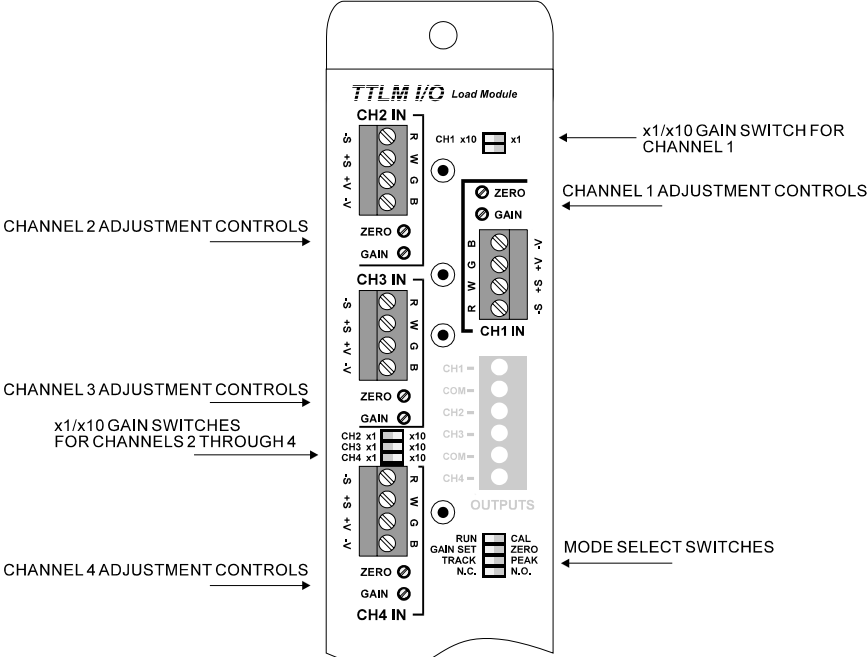

Figure 8

- Step 1) Make sure that the RUN/CAL switch is set to RUN.
- Step 2) Make sure that the GAIN SET/ZERO switch is set to ZERO.
- Step 3) Insure that the external probe signal is turned on before the load is generated and turned off after the operation is complete. If the logic of the probe is reversed, use the N.C./N.O. switch to invert the probe signal logic or adjust the probe accordingly.
- Step 4) Set the TRACK/PEAK switch to the desired mode. While in TRACK mode each channel's output will follow the loading on the sensor as the load on the machine increases and decreases. In PEAK mode, the output will increase to the highest load level and remain at that voltage until the probe is released.

## **Definition of Terms**

<b>Alarm</b>	A reading that is out of the high or low limit range causing the relay to de-energize. Once alarmed, the relay opens to stop the press/machine.
<b>Balance</b>	The balance adjustment electronically zeros the sensors under a no load condition.
<b>Calibration Number</b>	A gain reference value that is adjusted to obtain accurate tonnage readings.
<b>Calibration</b>	The process in which the TTLM unit is adjusted to read the same tonnage as the reference load cells.
<b>Triggering Device (Probe)</b>	A switching input to the unit allowing tonnage to be read at a certain position in the stroke. It is usually obtained from a rotary cam switch, programmable limit switch or a proximity switch. <b>(Only 24 VDC devices.)</b>
<b>Compression</b>	The force measured by the sensor or load cell by compression. The sensor location to measure compression is usually found in the rear of a C-Frame press or on a Pitman arm.
<b>Gain / Span</b>	Gain, also called Span, is the amount of amplification applied to the sensor output. The gain is adjusted during calibration.
<b>Reverse Load</b>	The “snap through” or damaging negative forces occurring in the machine. Typically, the snap through rating is 10% of the capacity of the press.
<b>Shut Height</b>	The distance from the top of the bed of the press to the bottom of the ram when on BDC.
<b>Track Mode</b>	When using the track mode, the output will cycle between 0 and 9VDC during the press stroke. The value goes back to 0V when there is no load.
<b>Peak Mode</b>	When using the Peak Mode the output will hold the highest force seen during the time the probe switch is on.
<b>Tension</b>	The force measured by the sensor when the press frame stretches





# Appendix A

## SENSORS PLACEMENT & INSTALLATION



NOTES:

- 1) (2) SENSORS REQUIRED
- 2) (2) SENSOR ENCLOSURES ARE INCLUDED. THESE HELP PROTECT THE T400 SENSOR GAUGES. THESE ENCLOSURES INCLUDE 1/2" KNOCK-OUT HOLES. IF CONDUIT IS USED, WE SUGGEST USING 1/2" STRAIN RELIEFS IN THE KNOCK-OUT HOLES.

### SENSOR PLACEMENT

Sensor location must be determined. You have two locations. The front or the rear of the press. (Shown in the shaded area.)

#### HOW TO DETERMINE THE BEST LOCATION

\* MEASURE THE REAR THICKNESS

\_\_\_\_\_ REAR X 3 =

\* MEASURE THE FRONT THICKNESS

\_\_\_\_\_ FRONT

If the front thickness is smaller than value in , then mount sensors in the front. (This is the most common.) If the front thickness is larger, then place the sensor in the rear. Adjust the input connection for compression readings instead of tension.

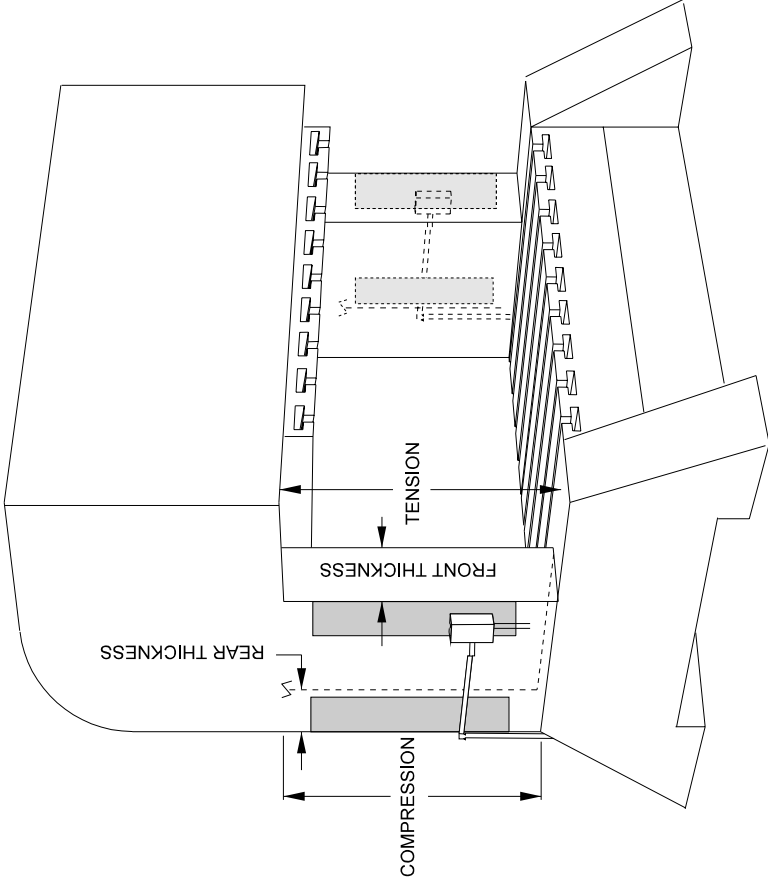

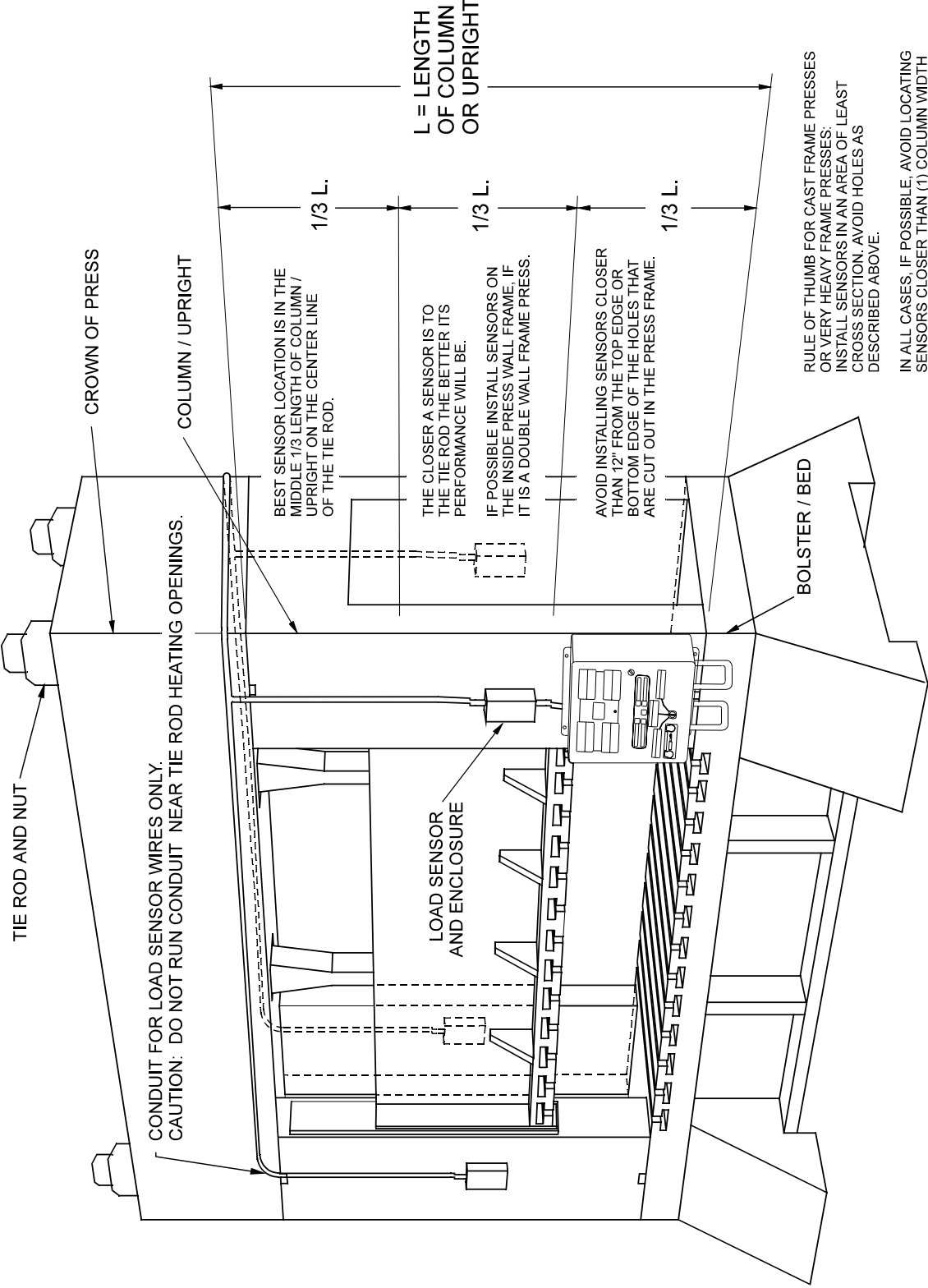

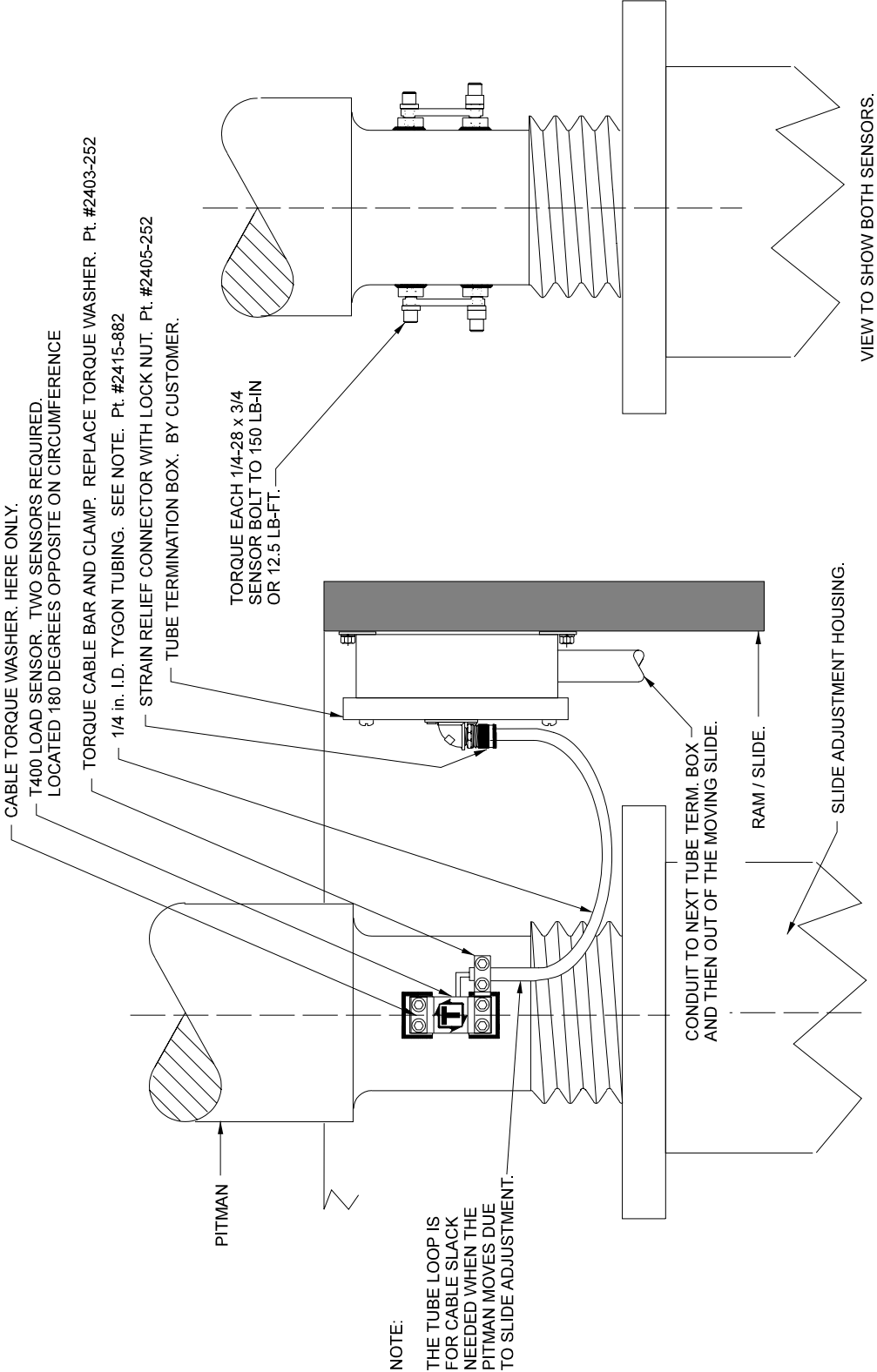

## USING THE T400 SENSOR INSTALLATION FIXTURE KIT No. 1977-749

### (METRIC INSTALLATION FIXTURE KIT No. 1974-749)

#### *DRILL AND TAP METHOD FOR MOUNTING SENSORS*

BE SURE THE SENSOR LOCATION FOLLOWS THE BEST LOCATION DESCRIBED ON THE PREVIOUS PAGES.

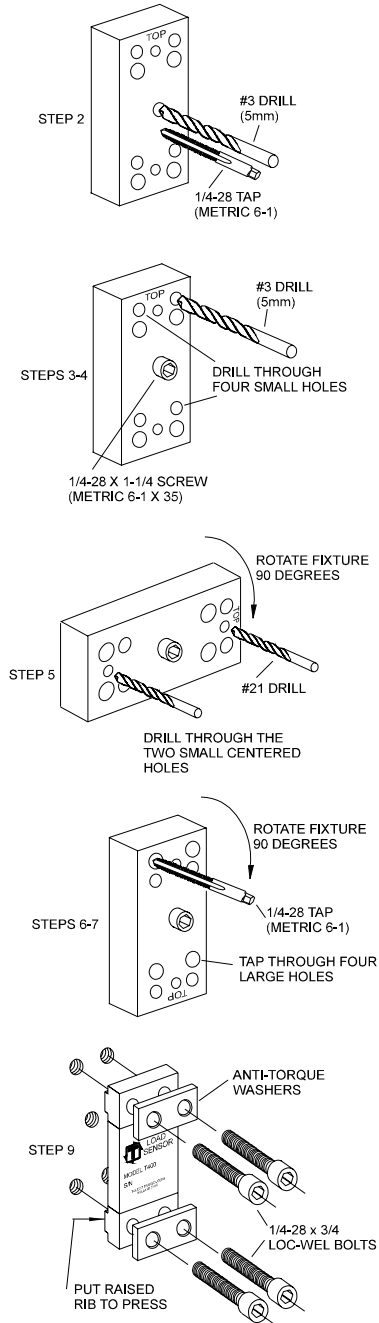

- STEP 1** Remove all paint and grease from sensor mount area. If the machine surface is flat (total indicated reading of .002”) and smooth (125 μ in.) the load sensor can be bolted directly to the surface
- STEP 2** Drill and tap the center hole for mounting the fixture to the press member. This hole should be ½ inch (13mm) deep.
- STEP 3** Bolt the fixture to the press member using the ¼-28 by 1-¼ inch (M6-1 x 35) long socket head cap screw in the center of the fixture.
- STEP 4** Insert the number 3 drill (5mm) into the smaller corner hole and drill out all four holes to a depth of ¾ of an inch (19mm.)
- STEP 5** Loosen the fixture. Rotate the fixture 90 degrees clockwise. Tighten the center screw of the fixture. Insert the number 21 drill into the small centered hole and drill out both holes to a depth of 3/8 of an inch. These holes are for mounting the sensor enclosure. The fixture does not allow for tapping these holes. They are tapped without the fixture. Enclosure mounting is not done in metric.
- STEP 6** Loosen the fixture. Rotate the fixture another 90 degrees clockwise such that the larger corner holes line up with the holes drilled in Step 4. Insert a tap to be sure the holes line up. Lock the fixture in place by tightening the center screw.
- STEP 7** Insert the tap into the larger tap guide holes and tap each hole.
- BE SURE TO USE PLENTY OF TAPPING FLUID.**
- STEP 8** Remove the fixture and repeat Steps 1-7 for each additional sensor mounting position.
- STEP 9** Mount the sensor with the raised rib to the press. The anti-torque washers should go between the screw and the sensor body. Torque each ¼-28 x ¾ in. long socket head cap screw to 150 LB.-IN or 12.5 LB.-FT.



## USING THE T400 SENSOR INSTALLATION FIXTURE KIT No. 1977-749

### WELD PAD METHOD FOR MOUNTING SENSORS

BE SURE THE SENSOR LOCATION FOLLOWS THE BEST LOCATION DESCRIBED ON THE PREVIOUS PAGES.

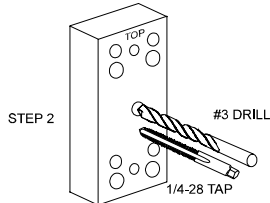

STEP 1 Remove all paint, grease, and or rust from surface to be welded. (Surface should be flat T.I.R. 1/32 of an inch.)

STEP 2 Drill and tap the center hole for mounting the fixture to the press member. This hole should be 1/2 inch deep. (Optional)

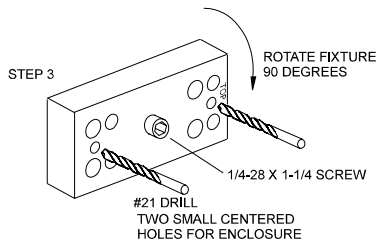

STEP 3 Bolt the fixture to the press member using the 1/4-28 by 1-1/4 inch long socket head cap screw in the center of the fixture. Orient the fixture as shown and drill out the #21 holes to a depth of 3/8 of an inch for the enclosure mounting. The fixture is not used for tapping these holes. (Optional)

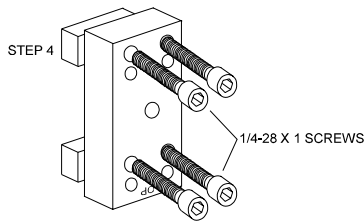

STEP 4 Remove the fixture from the press member. Bolt the weld pads to the fixture with 1/4-28 by 1 inch long socket head cap screws provided. Reattach the fixture with the weld pads bolted on using the center hole as in Step 3. Orient the fixture as shown.

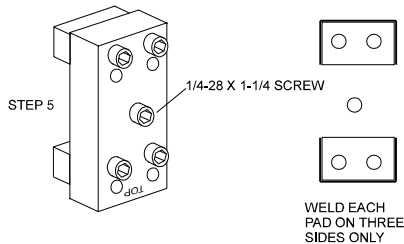

STEP 5 Weld the weld pads to the press member. (BE SURE TO ONLY WELD THE WELD PADS ON THREE SIDES AS SHOWN.) A single pass is sufficient. Do not remove the fixture until slag is removed and or assembly has cooled. When welding cast iron, use a dry nickel rod such as: Lincoln Electric "Soft Weld", Hobart "NI Cast 99", or MB Weld Prod. "MG 210. Strike arc on steel then nuddle into the cast iron.

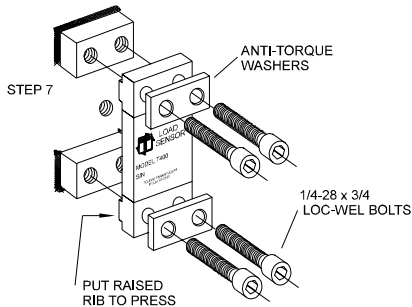

STEP 6 Remove the weld fixture. DO NOT WELD AFTER FIXTURE IS REMOVED. The 4 screws holding the pads to the fixture and the 1 center screw may be discarded. DO NOT USE THE FOUR 1 INCH LONG SCREWS TO ASSEMBLE SENSOR. The sensor kit contains four 3/4 inch long screws for assembling the sensor to the press member. Weld pad surface must be clean – no weld bumps, scratches, etc. Be sure the weld pad tapped holes are clean and bottom of holes are free of weld flash.

STEP 7 Mount the sensor with the raised rib to the press. The anti-torque washers should go between the screw and the sensor body. Torque each 1/4-28 x 3/4 in. long socket head screw to 150 LB.-IN or 12.5 LB.-FT.

# SENSOR ENCLOSURE MOUNTING

USE 10-32 TAP IN THE TWO 3/8" DEEP HOLES THAT WERE DRILLED WITH THE FIXTURE IN THE PREVIOUS INSTRUCTIONS. MOUNT THE ENCLOSURE TO THE PRESS MEMBER AND RUN 1/2" INCH CONDUIT TO THE LOAD MONITOR ENCLOSURE.

RUN SENSOR CABLE THROUGH CONDUIT. PLACE SENSOR ON MOUNTING HOLES. PLACE ANTI-TORQUE WASHERS OVER SENSOR HOLES. SCREW IN SENSORS BOLTS, (4) EACH, FINGER TIGHT. USE ONLY THE 1/4-28 x 3/4" "LOC-WEL" BOLTS THAT ARE IN THE SENSOR PACKAGE. TORQUE EACH 1/4-28 x 3/4" SCREW TO 150 LB.-IN. OR 12.5LB.-FT. ASSEMBLE BOX COVER.

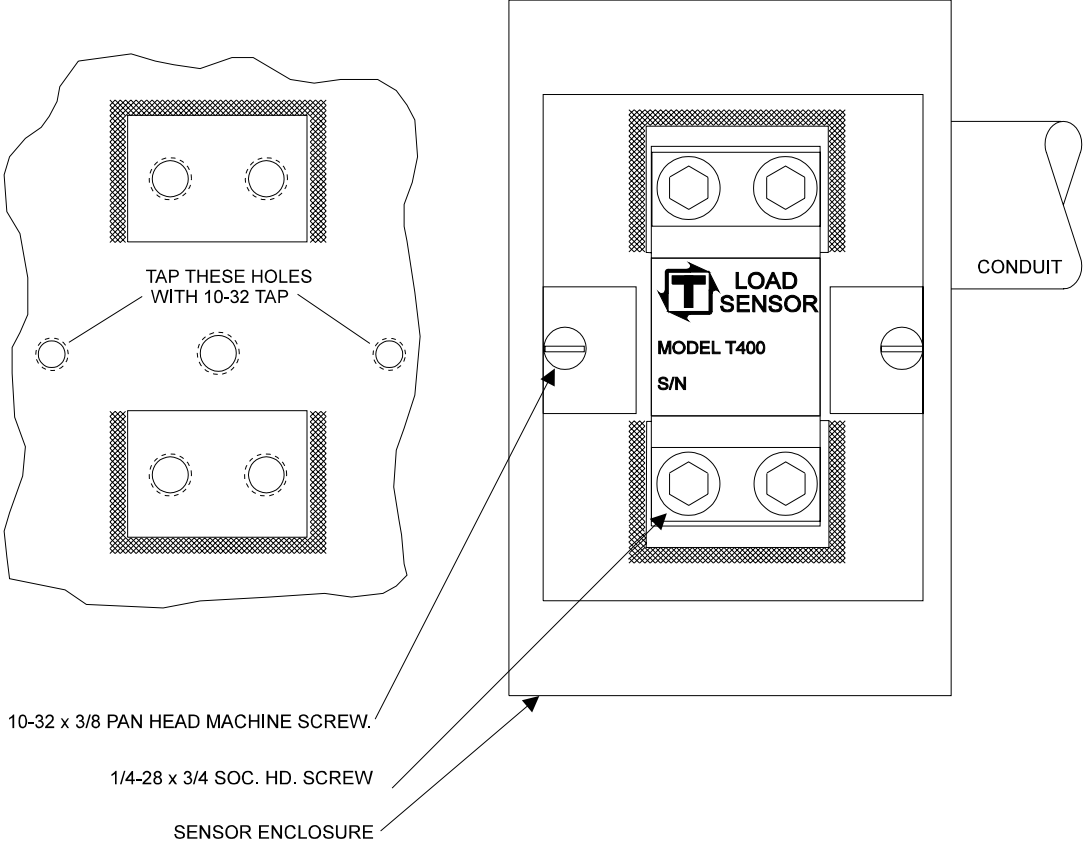



# Appendix B

## Replacing a T400 Sensor



**Replacing a T400 Sensor**

To replace a T400 Sensor locate the correct channel for that sensor. In most cases they are installed as:

- Left Rear – Channel 1
- Right Rear – Channel 2
- Left Front – Channel 3
- Right Front – Channel 4

- Step 1) After pulling the new sensor through, make sure it is tightened down to 150 in/lbs or 12.5ft/lbs. If you don't do this, your new tonnage readings may end up being lower.
- Step 2) Refer to steps 1 through 3 of Connecting Sensors to the TTLM on page 6 for stripping and crimping the cable.
- Step 3) Make sure your cable is terminated correctly at the TTLM side. The wire colors should be the same as the replaced sensor.
- Step 4) Toggle the mode select switches to CAL, ZERO, TRACK:

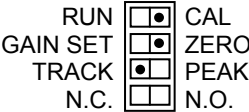

- Step 5) Locate the analog output pins from figure 8 on page 13. These will be from 0-10vdc. Locate the channel which the sensor was replaced. Now locate the balance pot for that channel. Adjust the balance pot for that channel until your voltmeter reads 0.00vdc. Do not adjust the gain pot or your readings will not be accurate. (Your unit will go out of calibration if the gain is adjusted.)
- Step 6) Toggle the switches to RUN, ZERO, PEAK and wait for three minutes before cycling the press.

