

**PW Series Monitor
Installation, Calibration &
Operation Manual**

Revision C

LIMITED WARRANTY

This unit is warranted by the manufacturer, Toledo Transducers, Inc., to be free of defects in workmanship and material for one year from date of manufacturer's shipment. This warranty is limited to repairing or replacing products which manufacturer's investigation shows were defective at the time of shipment by the manufacturer. All products subject to this warranty must be returned F.O.B., Toledo Transducers, Inc., 6834 Spring Valley Drive, Holland, Ohio 43528, for examination, repair, or replacement.

THE EXPRESS WARRANTY SET FORTH HEREIN IS IN LIEU OF ALL OTHER WARRANTIES, EXPRESS OR IMPLIED, INCLUDING WITHOUT LIMITATION ANY WARRANTIES OF MERCHANT-ABILITY OR FITNESS FOR A PARTICULAR PURPOSE. ALL SUCH WARRANTIES ARE HEREBY DISCLAIMED AND EXCLUDED BY THE MANUFACTURER.

Repair or replacement of defective products as provided above, is the sole and exclusive remedy provided thereunder. The manufacturer shall not be liable for any further loss, damages, or expenses, including incidental or consequential damages, directly or indirectly arising from the sale or use of this product.

Any unauthorized repair voids this warranty.

There are no warranties that extend beyond those expressly set forth herein.

Table of Contents

Limited Warranty	1
Introduction to Installation	4
Mounting the PW Series Monitor	5
Connecting the Sensor Cables	6
Cam Input Wiring.....	9
Cam Switch Operation.....	11
Shut Down Relay and AC Power Wiring	13
Initial Switch Settings.....	15
The Press Capacity	16
The Number of Decimal Places	16
Shut Down Immediate or Delayed	16
Set the Threshold	16
Preparing the PW Series Monitor for Calibration	17
Computer Input Plug.....	21
Monitor address for computer connection.....	22
Connections to Computer and Monitors Plant Wide.....	23
Introduction to Calibration.....	25
Record All Serial Numbers.....	26
Tighten All Sensors	26
Check Sensor Shields	26
Remove Board Covers.....	26
Set Capacity.....	27
Find Shut Height	27
Place Cells	27
Cycle The Press.....	27
Enable External Reset.....	28
Put Monitor in Calibration Mode.....	28
Adjust Zero-Balance.....	28
Put Monitor into Run Mode.....	29
Adjust Gain.....	29
Record Calibration Numbers.....	29
Make Linearity Check.....	30
Check Alarms	30
Calibration Form.....	Insert

Introduction To Operation	31
Chapter One: Using the Outside Controls	32
Three Position Function Selector	32
Resume Automatic Monitoring	32
Manual Operation.....	32
Begin Automatic Operation.....	32
Push Button Selectors	33
Show High Alarms	33
Show Low Alarms	33
Show Benchmark Tons	33
Check Calibration.....	33
Show Count.....	34
Show Reverse Tons	34
Signal Outputs.....	34
Chapter Two: Alarms and Flashing Displays	35
Capacity Alarms	35
High and Low Alarms	35
Phantom Alarms.....	35
Drift Control Alarms.....	35
Chapter Three: Inside Controls	36
Supervisor Controls	36
External Reset On.....	36
External Reset Off.....	36
Reset Tripped Alarms	36
Tonnage Display On.....	36
Tonnage Display Off	36
Regular PW Nuisance Controls	37
PW PLUS Left & Right Controls	38
OPTIONAL Automatic Target Tonnage Recall Controls	39
Storing A Job.....	39
Recalling A Job.....	40
High Limits.....	40
Low Limits.....	40
Addendum: Installing T400 sensors	41

Introduction to the PW Series Monitor - Installation

The Installation manual is the first part of the full PW manual that includes the Calibration and Operation manuals.

It will assist you in all the steps towards installing your PW.

For further assistance please contact the Toledo Transducers Inc. Technical Service Department at 1-800-T-TOLEDO.

Mounting the PW Series Monitor

The PW Series Monitor is an electronic instrument and must therefore be protected from physical stresses such as shock and vibration. Shock mounts are provided with every PW Series Monitor for this purpose. Failure to use these shock mounts may result in premature failure of the instrument and possibly void your warranty.

The PW Series Monitor may be mounted directly to the press, or to an adjacent structure. It should be positioned so that the display is easily read, and the instrument is readily accessible. Figure 1a below provides the mounting dimensions and demonstrates the proper attachment of the provided shock mounts.

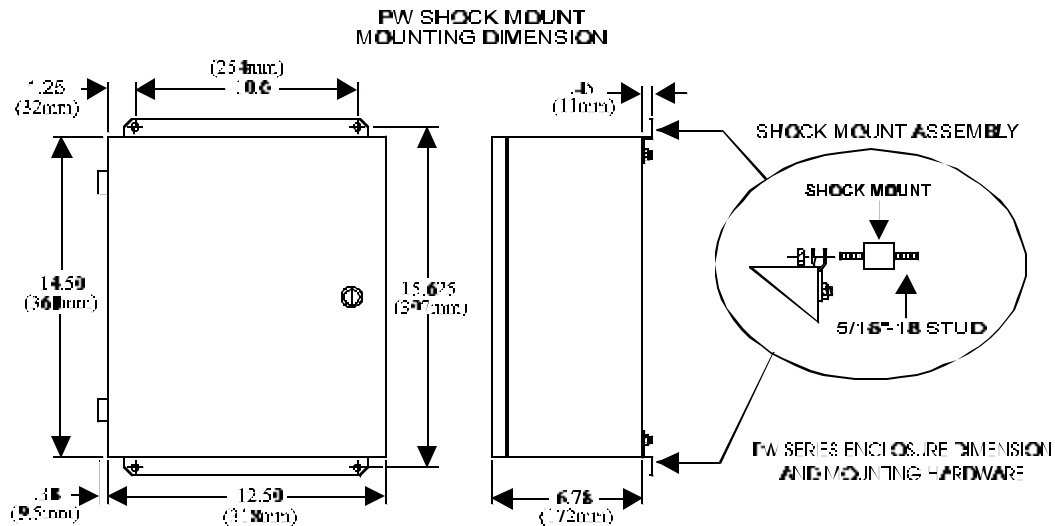

Figure 1a

An optional flush mounted installation is possible as show in Figure 1b. This application does not use the shock mounts mentioned above.

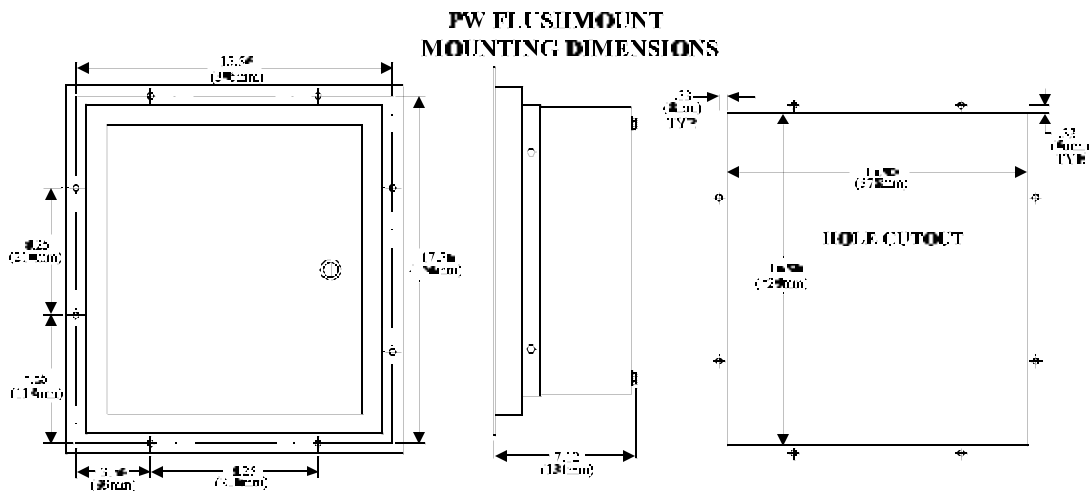

Figure 1b

Connecting the Sensor Cables

This section discusses the physical wiring of the sensors to the PW Series Monitor. It does not discuss sensor mounting or placement due to the highly technical and lengthy nature of this issue. Refer to the T400 sensor installation section at the end of this manual for more information.

Sensor cable on the outside of the PW enclosure should be protected with an adequate flexible conduit. Rigid conduit is not recommended as it may negate the function of the shock mounts used to secure the enclosure to the press or other structure.

The sensor cables should enter the PW enclosure through the leftmost hole on the bottom of the enclosure. This hole enters the inner chamber shown in Figure 2. About two feet of cable should extend into the enclosure.

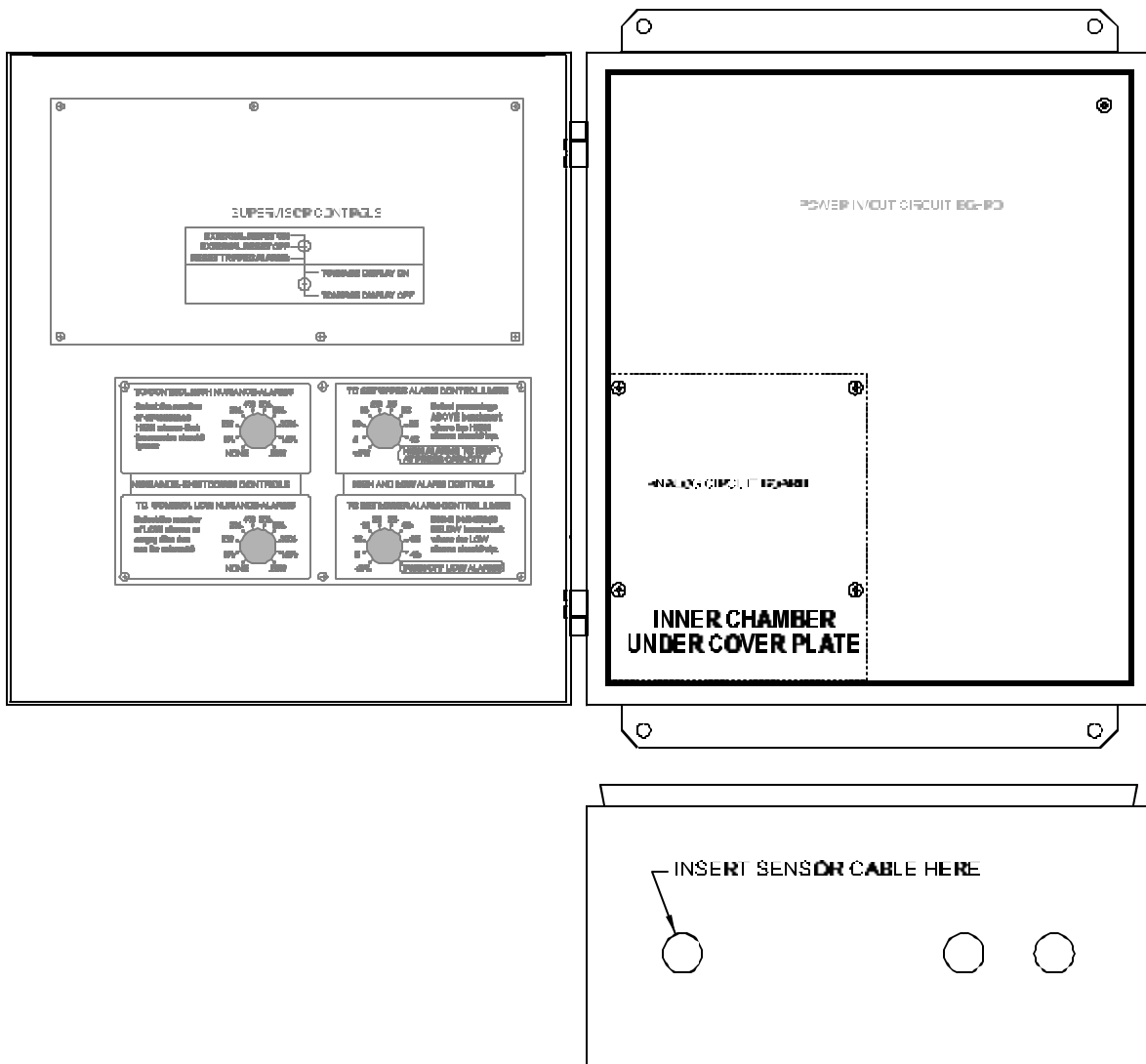

Figure 2

Sensor Connection Guidelines

- 1). Strip the sensor cable as shown in Figure 3.

Be sure not to nick any of the signal conductors or strip the shield completely away. At least ½ inch of cable shield should be exposed for proper insertion in to the wire lug.

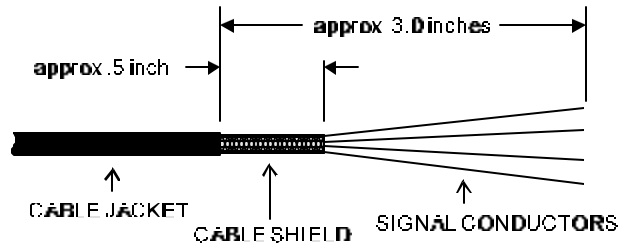

Figure 3

- 2). Insert the cable through the lug as shown in Figure 3a.

Make sure the cable shield is aligned with the portion of the wire lug which will be crimped.

- 3). Next, crimp the lug on to the cable shield, do not crimp too tight and risk smashing the wires. This could cause them to short to ground. Figure 3b shows a side view of the completed operation after crimping.

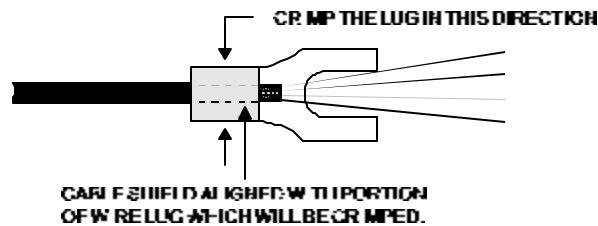

Figure 3a



Figure 3b

Note: If your sensor is not double shielded with both foil and a braid, electrical noise may affect your output readings.

Sensor Connection Guidelines Cont.

Strip the individual wires and attach them to the sensor input plug. Wire attachment is described in Figure 4.

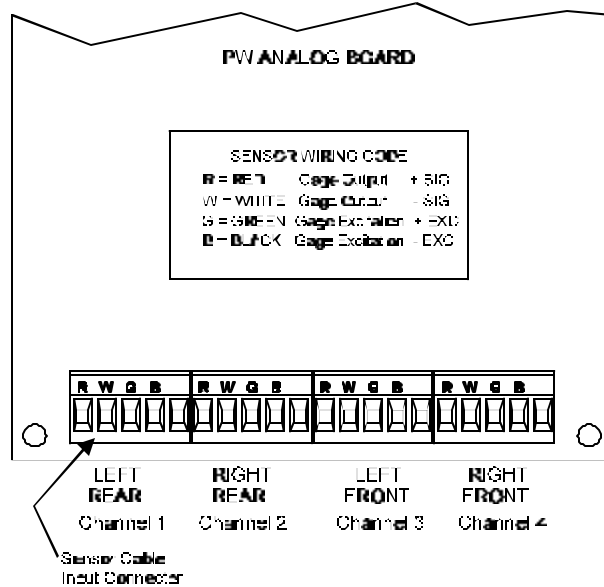

Figure 4

You should now have an assembly similar to the one shown in Figure 5. Plug the sensor input plugs into the appropriate headers on the Analog Input circuit board, attach the lugs to the chassis and sensor connection is complete.

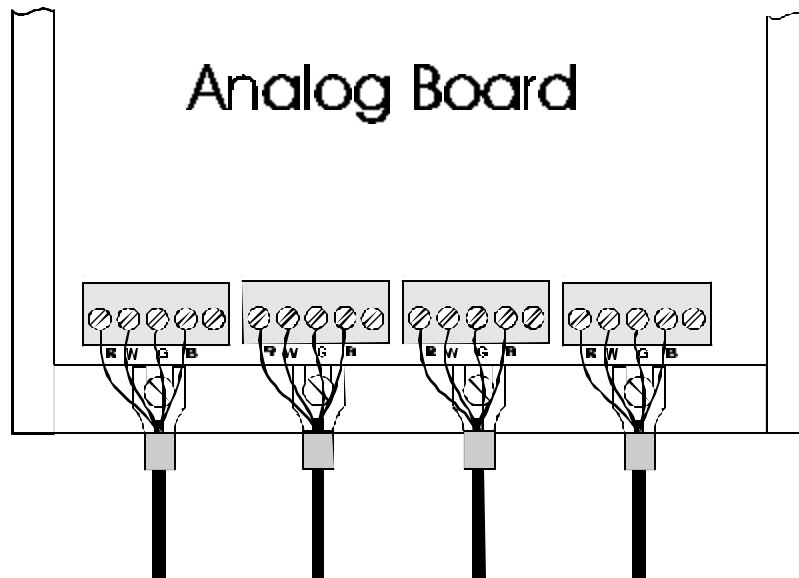

Figure 5

Cam Input Wiring

The cam, or probe input on the PW Series Monitor is used to indicate when a press stroke is in progress. Cam input switches are the most reliable method for triggering the PW Series Monitors. The PW unit can use a cam switch, PLS relay or proximity probe.

The cam input on the PW Series Monitors is found on the Power-I/O circuit board located behind the cover plate indicated in Figure 6. The connector is a 4-conductor plug and is labeled "PROBE INPUT".

Note: The Forging Press Monitor should use a cam input. If not, a low tonnage station may be ignored.

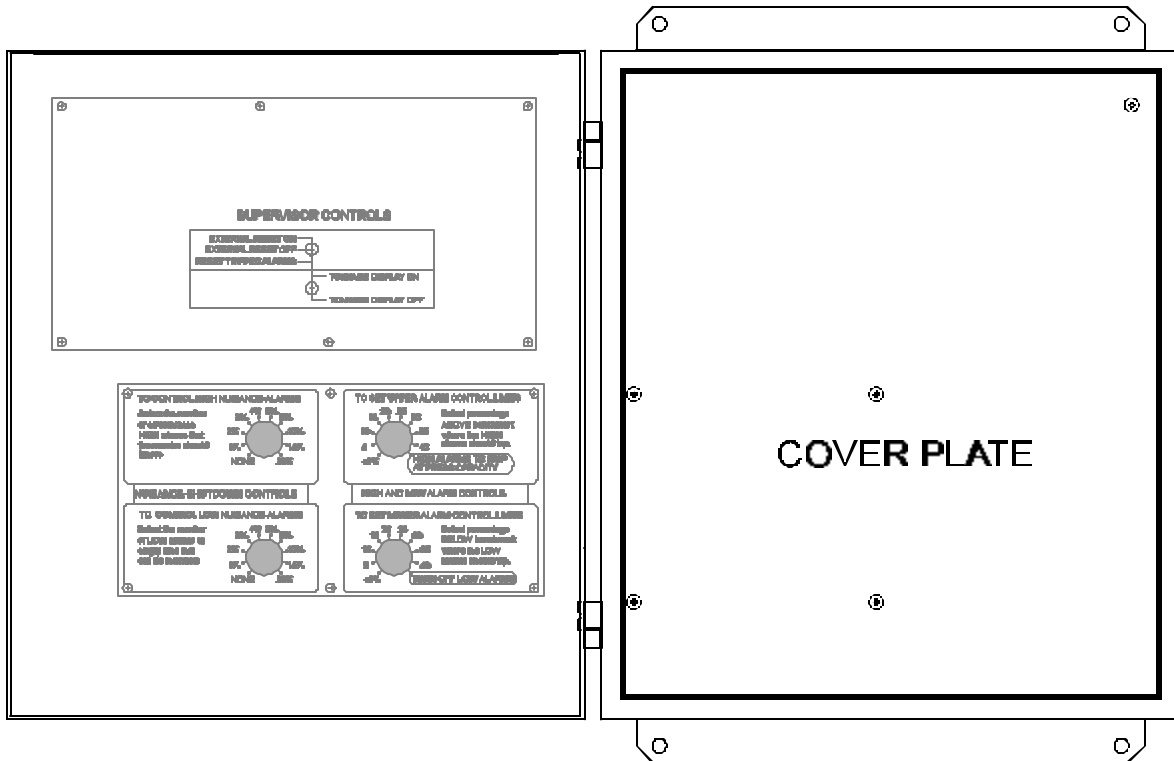

Figure 6

Cam Input Wiring cont.

Figure 7 shows the wiring for three of the most common configuration used for cam input with the PW Series Monitors.

Note: Normally- Closed (N.C.) cam switches and proximity probes may be used by changing DIP switch position number 3 to OFF

CAUTION: DO NOT CONNECT 110V TO THIS INPUT

To keep electrical noise from entering the monitor through the cam input, a shielded type cable must be used, and must be grounded to the press or PLC controls.

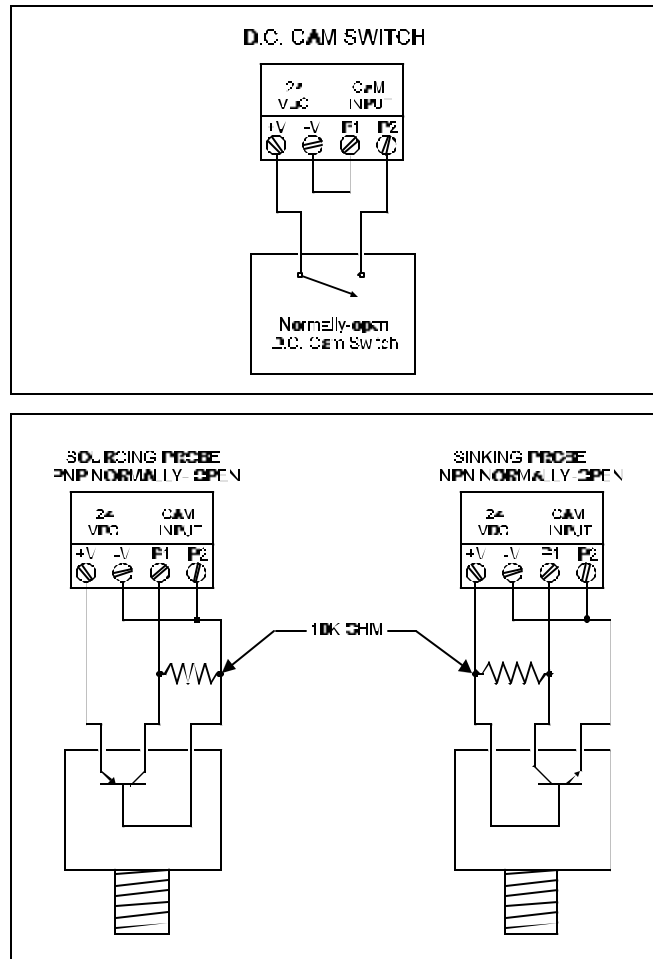

Figure 7

Cam Switch Operation

The operation of the cam switch should be such that it closes before the die contacts the part and remains closed until the load is removed. Figure 8 below shows the relationship of the cam switch signal to the press load level.

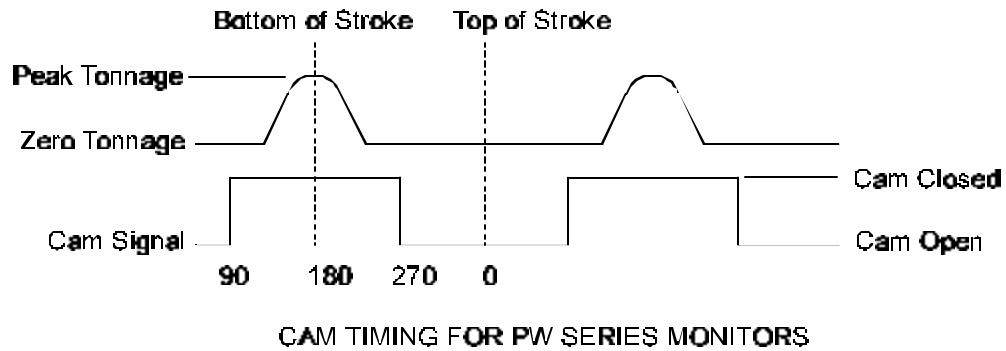

Figure 8

The circuit board to which the cam input is connected contains a bank of DIP switches. Switch #3 in this bank inverts the state of the cam switch as seen by the PW Monitor. This allows the use of N.C. switches, or probes as well as N.O. switches. Another helpful feature is the Probe LED also included on this circuit board. This LED will light when the cam switch is closed, and turn off when it opens. Figure 9 shows the Input/Output circuit board with these features labeled.

Note: When using a cam switch the threshold must be set to 00. Refer to Figure 13 under Initial Switch Settings.

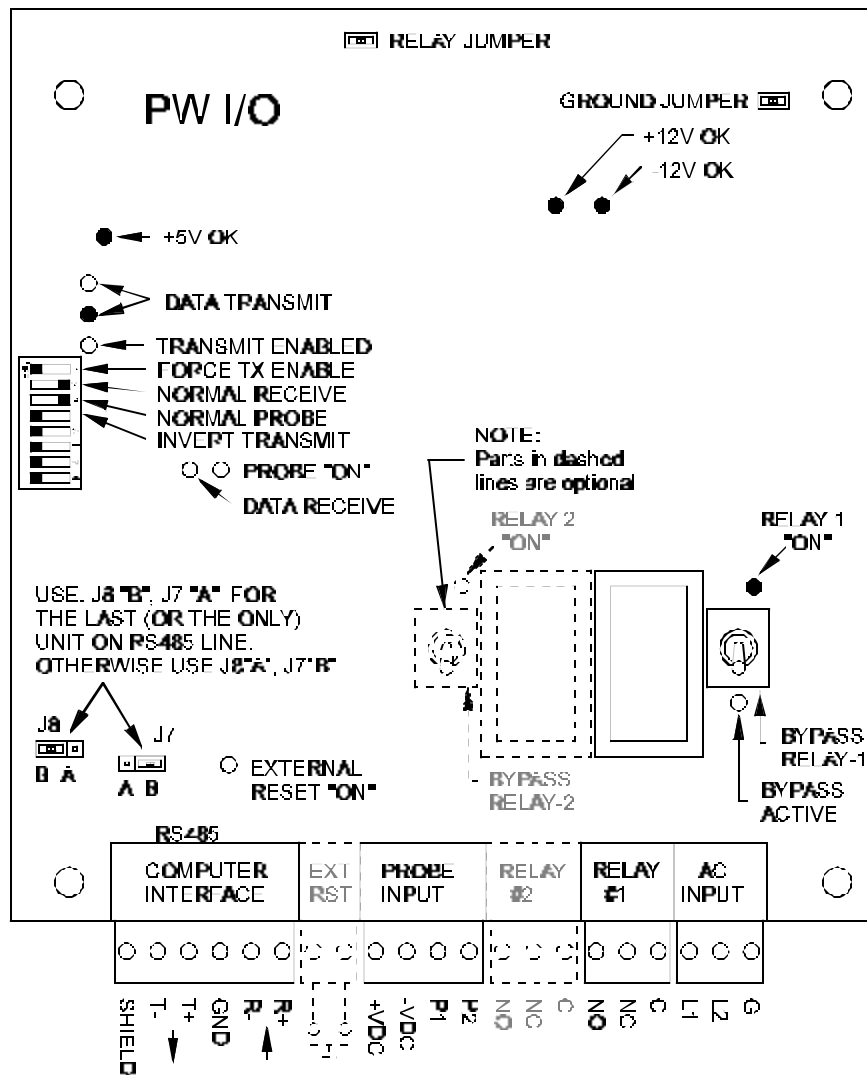

Figure 9

Shut Down Relay and AC Power Wiring

The shut down relay and AC power connectors are found in the same chamber as the cam input connector.

The shut down relay may be used to stop a press when an alarm condition is detected by the PW Series Monitor. The AC connector supplies power for the Monitor. The connectors for both of these circuits are located to the far right on the bottom of the Input/Output circuit board.

Figure 10 shows the wiring for both of these circuits. **Note: the shut down relay is a N.O. relay held closed when no alarm condition exists.** This means that the N.O. contacts are closed until an alarm condition occurs. We suggest wiring your press to the N.O. and C terminals. If you use the N.C. and C terminals the bypass switch is not operable and the press can run without the monitor.

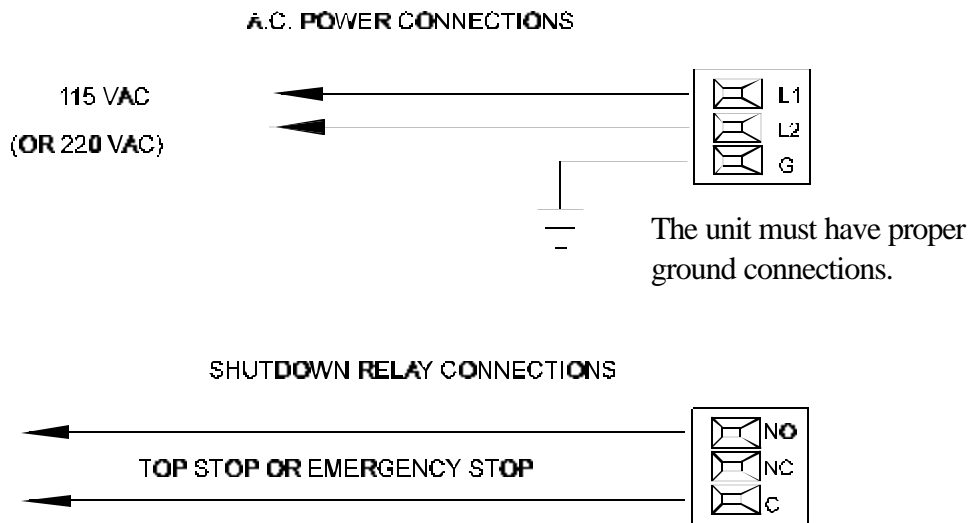

Figure 10

BYPASS SWITCH

When this bypass switch is on, the PW displays turn off to alert the user that the monitor is no longer effective. Although the N.C. and C contacts are not affected by the bypass switch, they may be used as a trigger to activate a light or external indicator.

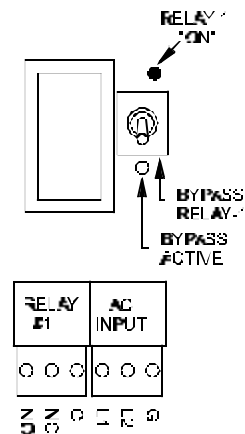

Figure 11

Shut Down Relay and AC Power Wiring Cont.

If the PW Monitor is to be powered with 220VAC, the AC power selector switch must be changed to accommodate the higher voltage. The switch is on the Power circuit board. Figure 12 shows the location of the switch.

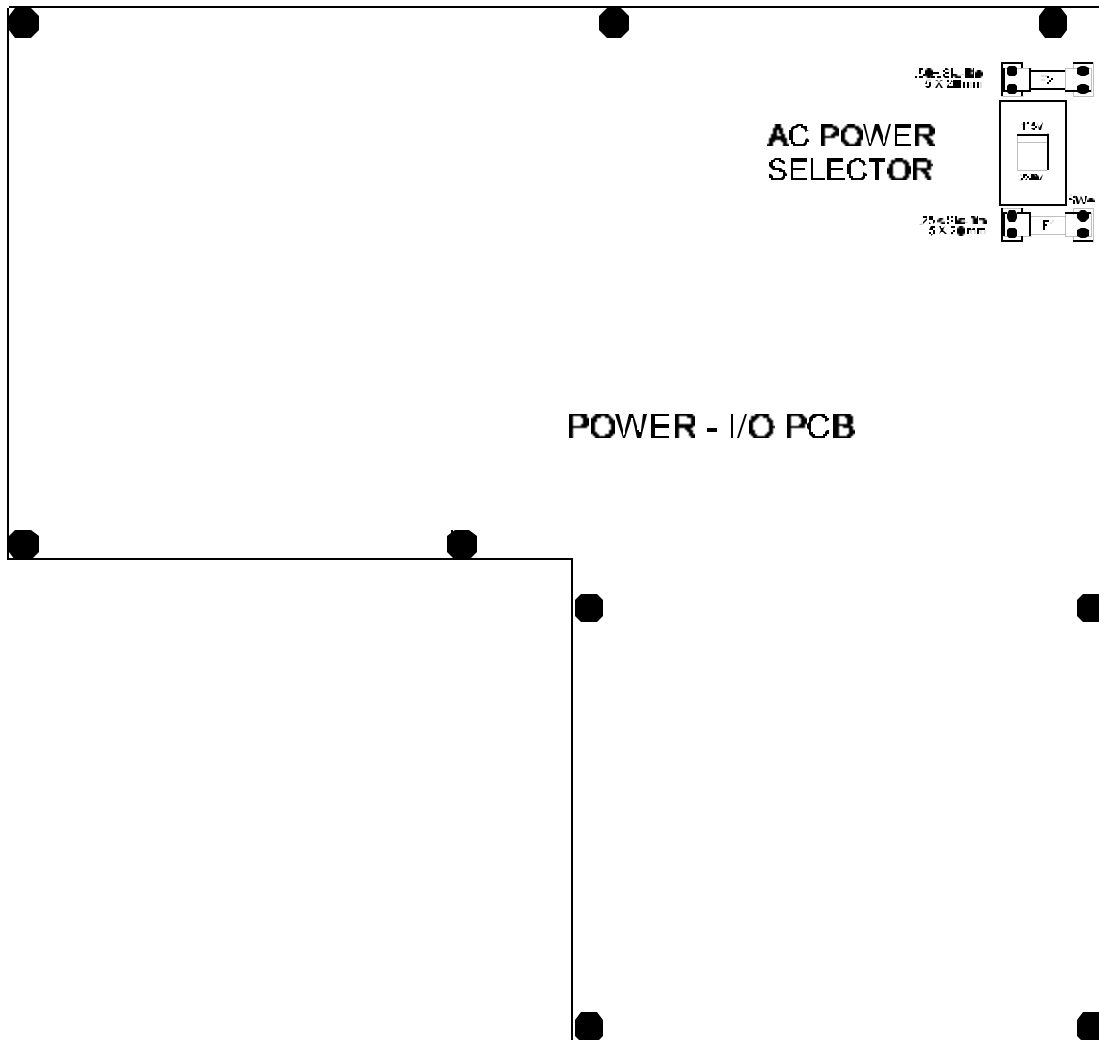

Figure 12

Initial Switch Settings

There are four parameters used by the PW Monitor. These parameters should be set before the instrument is calibrated, or used. These parameters are listed here:

- 1) Press capacity
- 2) Number of decimal places
- 3) Shut down immediate or delayed
- 4) Threshold percentage

These parameters are set using switches on the processor circuit board located under the Supervisor Control panel which is mounted to the door of the PW enclosure. The switches are depicted in Figure 13.

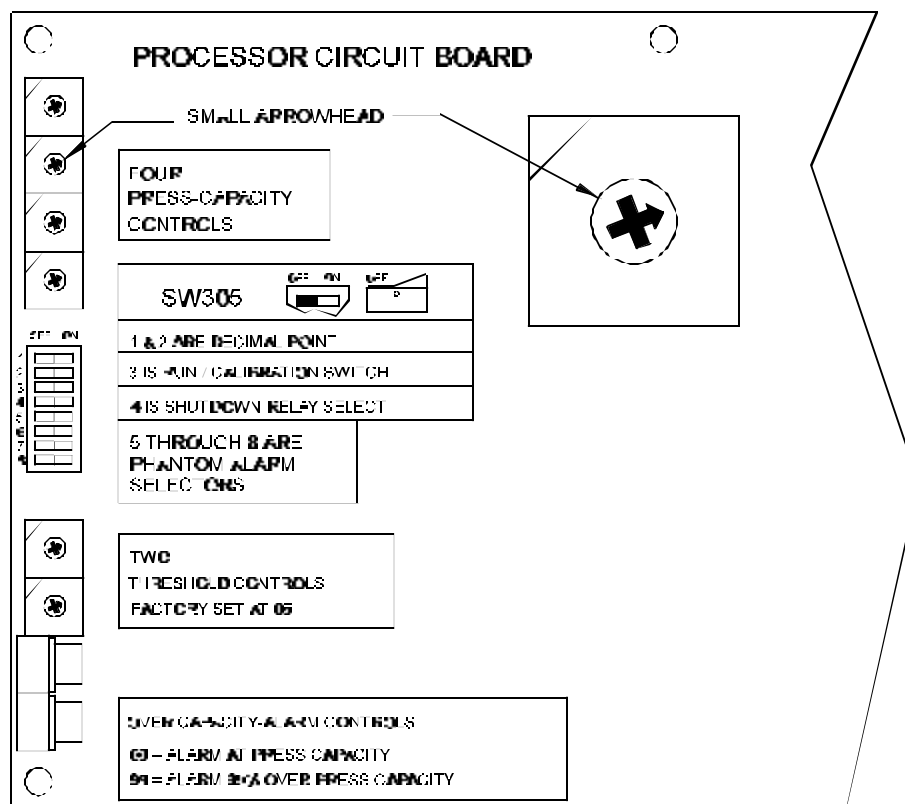

Figure 13

The Press Capacity

The press capacity switches scale the displayed tonnage to give an accurate reading for the press. These switches should be set exactly to the capacity of the press. If the capacity is less than 1000, the number dialed in should be left justified. For example, a capacity of 150 should be entered as 1500. The number of decimal places discussed next will compensate for this seemingly large value. Press capacities below 300 must have one decimal place.

The Number of Decimal Places

The number of decimal places may be set to 0, 1, 2, or 3 using switches 1 and 2 in the bank of DIP switches labeled SW305. Set the switches as follows for the number of decimal places desired:

SW305 1 & 2

9999 = 1 OFF 2 OFF
999.9 = 1 ON 2 OFF
99.99 = 1 OFF 2 ON
9.999 = 1 ON 2 ON

Figure 14

Shut Down Immediate or Delayed

Normally, the shut down relay in the PW Series Monitors opens after a press stroke when an alarm condition occurs. Switch #4 in the bank of DIP switches labeled SW305, when on, forces the relay to open immediately when an alarm condition is detected.

Set the Threshold

Although a cam switch or probe is the recommended method for triggering alarms, the PW Monitor is capable of triggering itself based on a threshold tonnage value. This threshold is set as a percentage of capacity using the threshold switches shown in Figure 13. If a cam switch or probe is used these switches must be set to 00. Otherwise, a typical threshold value is 6% of capacity or 06 on the switches.

If the unit is being used in a forging application, a low tonnage station may not be read. This is due to a low tonnage station under 6% of the capacity of the press. If a cam switch is used, every press stroke will be read including these low stations.

Preparing the PW Series Monitor for Calibration

This section does not discuss the actual calibration methods but instead details the controls on the PW Monitor that are used during calibration. The step by step Calibration procedure begins on page 25.

It is necessary to calibrate the PW Monitor to a specific press before it will accurately display and monitor the load on the press. This is often done using a portable load meter and load cells.

The first step for calibration is to put the PW Monitor into calibration mode. Switch #3 in the bank of DIP switches labeled SW305, when “ON”, places the PW Monitor into calibration mode. This switch is located under the Supervisor Control panel on the door of the PW Monitor. This is shown in Figure 15 below. The switch is accessible without having to remove the cover panel.

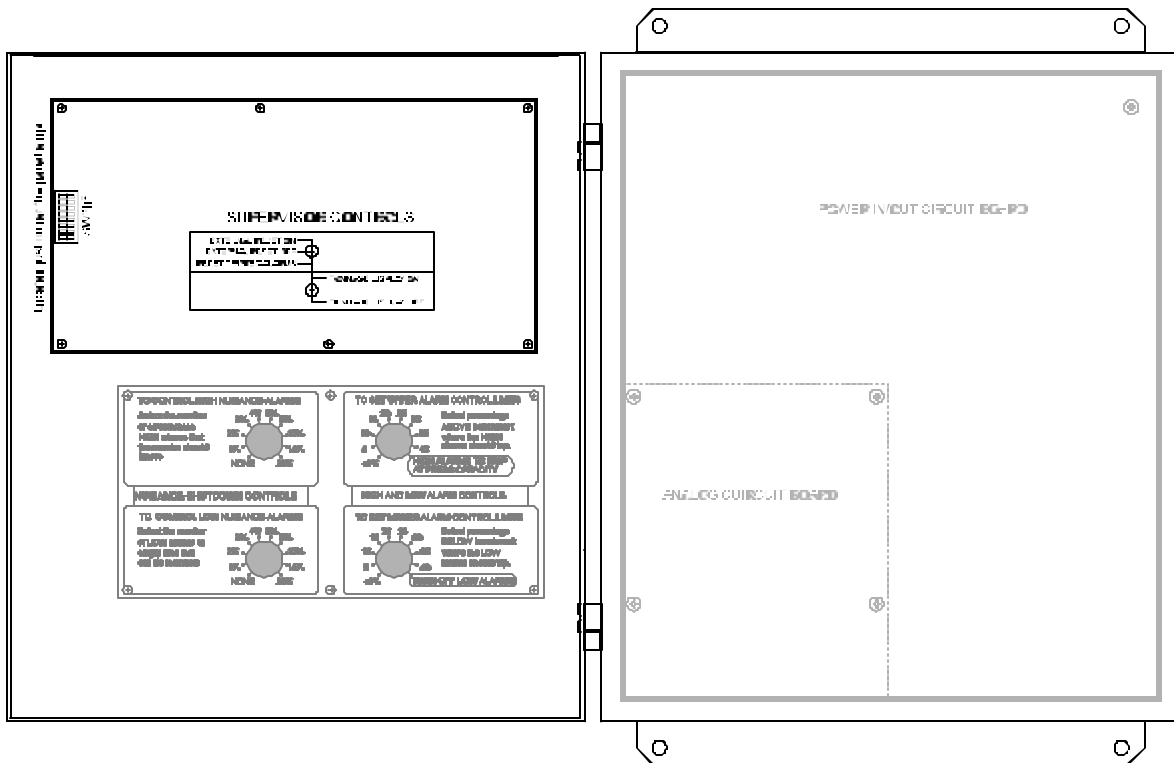

Figure 15

Preparing the PW Series Monitor for Calibration Cont.

Once in calibration mode the channels are ready to be "zeroed" or "balanced". **Balancing the channels must be done while the sensors are plugged into the PW Monitor.** A trim pot for balance is provided for each channel. These "pots" are located on the Analog Input board. Figure 16 depicts the location of the Analog Input board within the PW enclosure while Figure 17 on the next page shows the balance and gain controls for each channel.

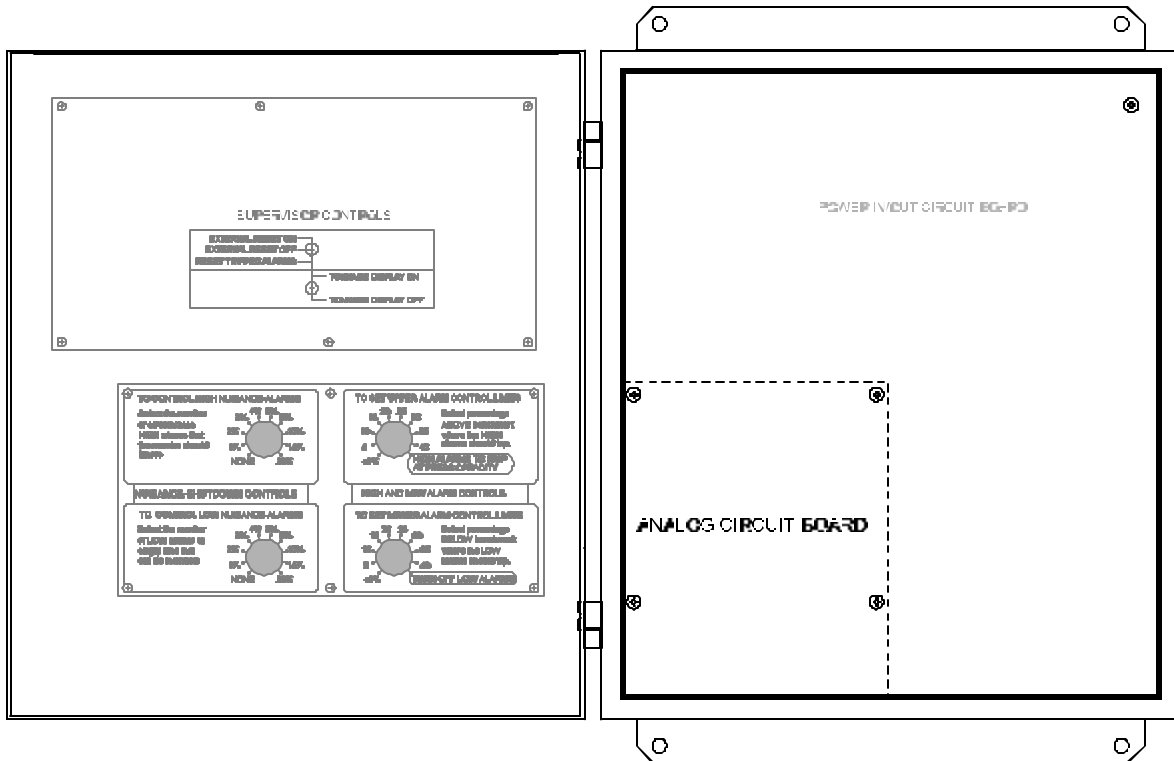

Figure 16

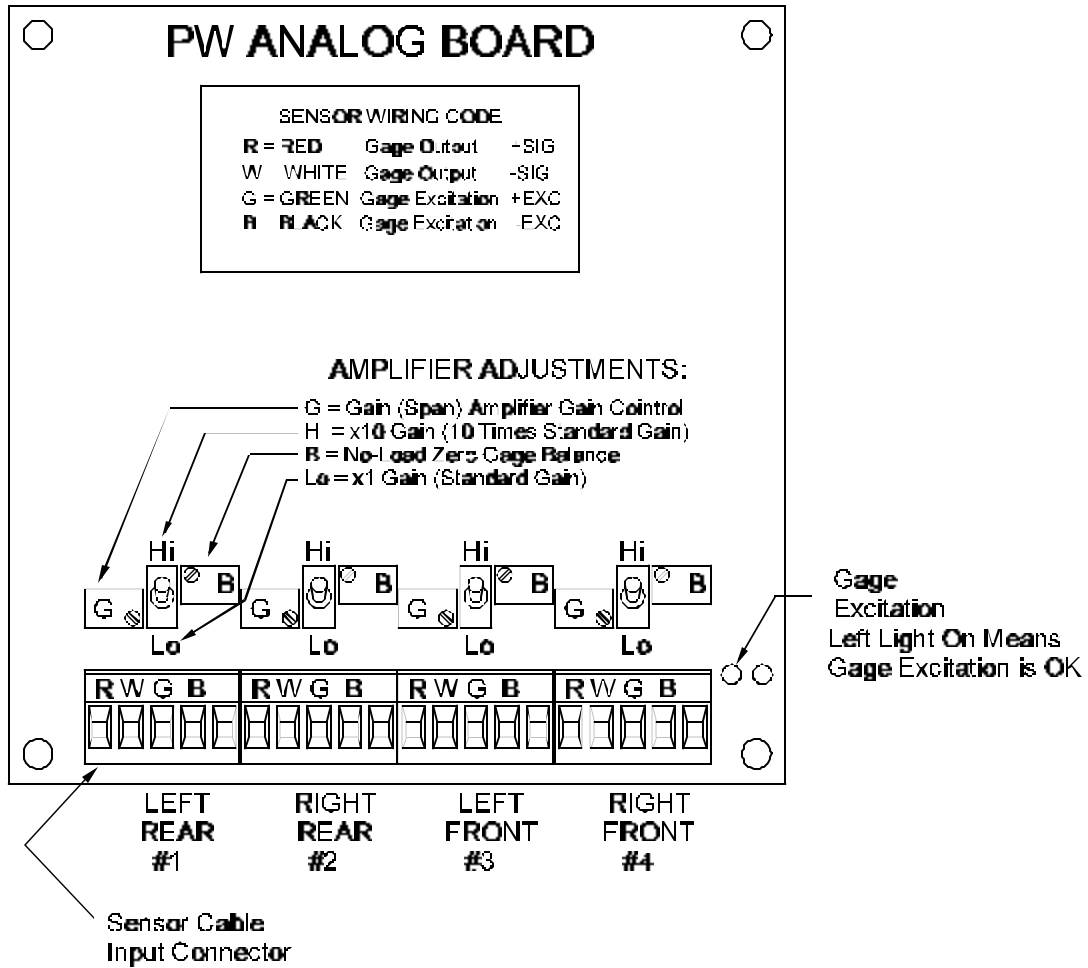

Figure 17

To balance any channel, simply rotate the associated balance pot (clockwise or counter clockwise) until the Percent Change display for that channel reads zero or very close to zero. Attaining a zero value is easiest when the machine is idle since the balance is affected by the loading on the machine. Figure 18 below graphically depicts the balance adjustments and the associated Percent Change display.

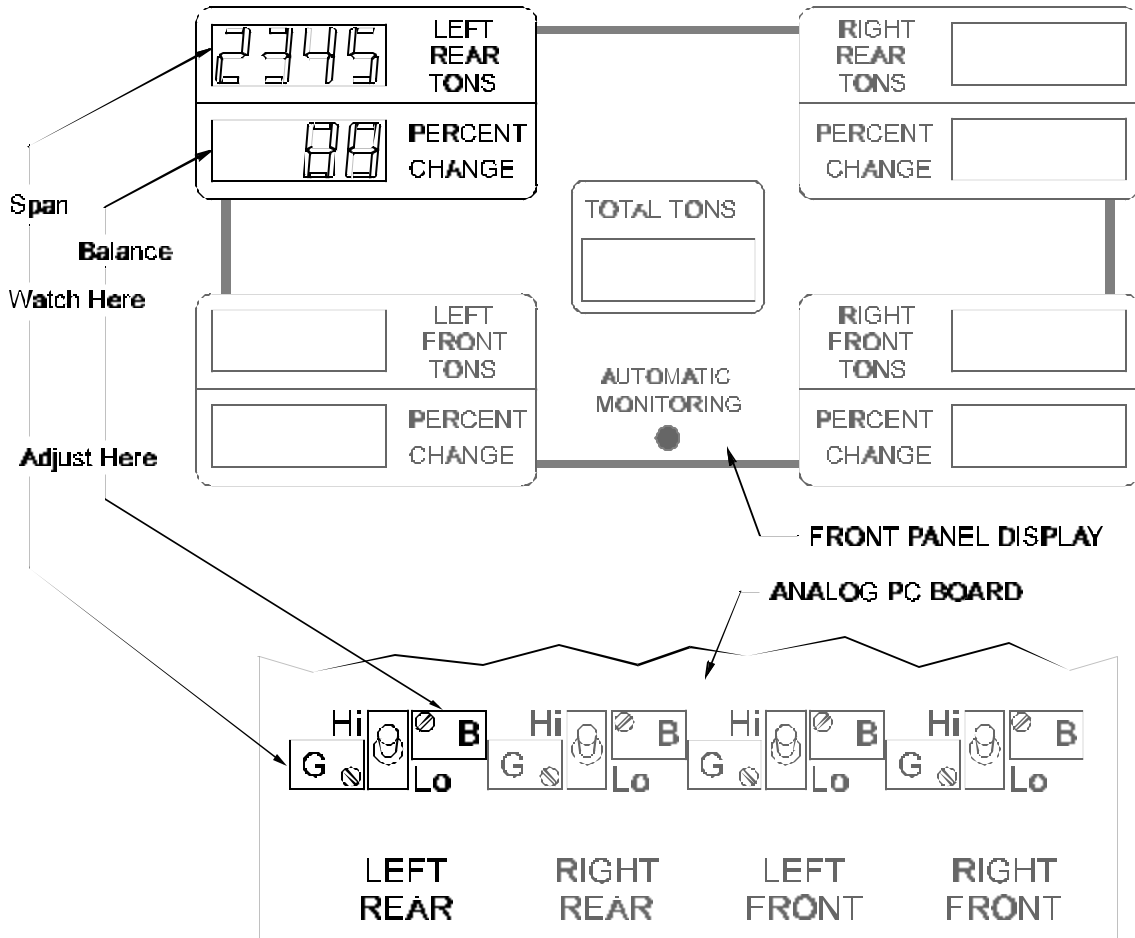
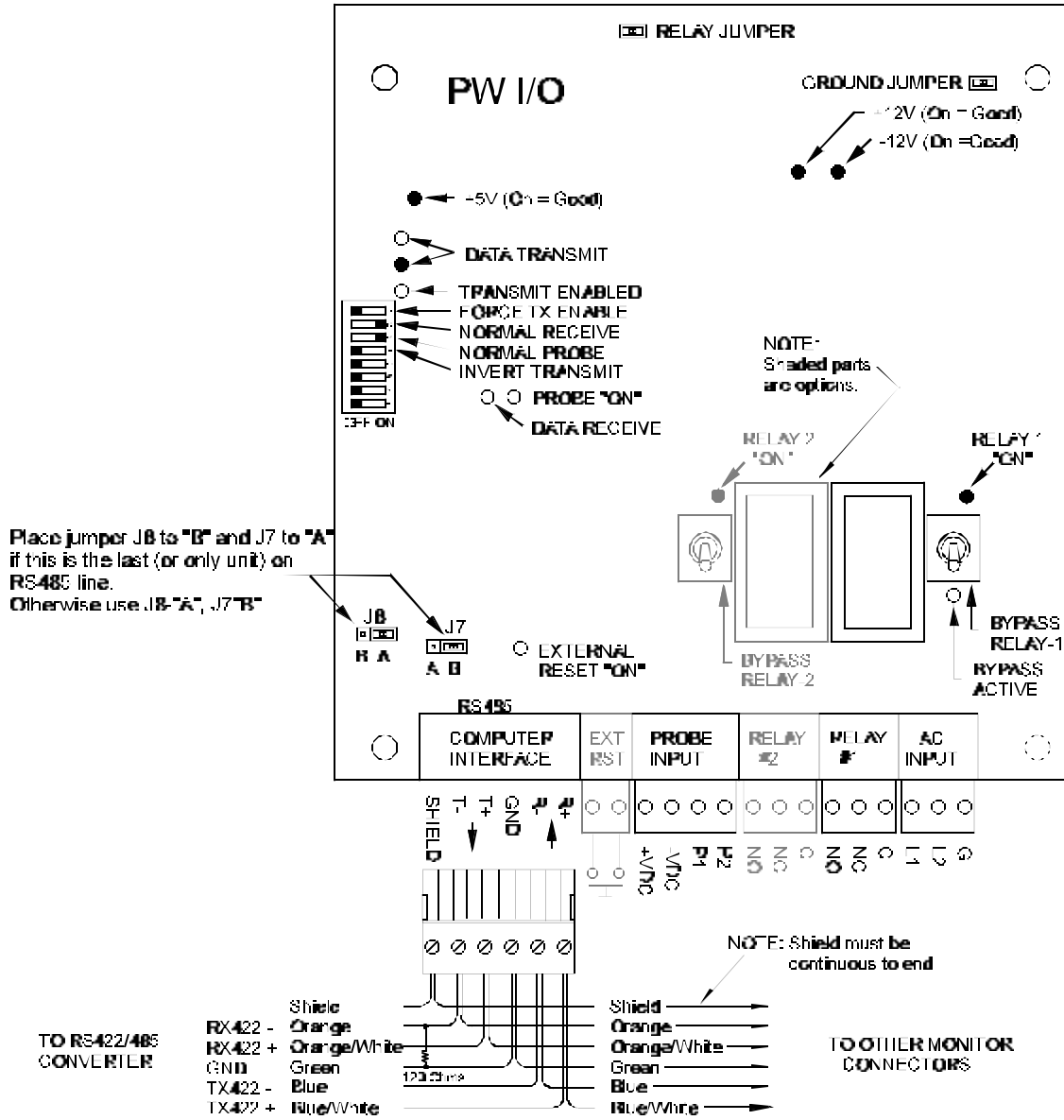

Figure 18

Once every channel is balanced the calibration may proceed. This may be done by Toledo Transducers, Inc. or by anyone familiar with portable load instruments and load cells. The procedure begins on page 25. The gain pots are used to set the gain (span) on the system.

When the calibration is complete return switch #3 of SW305 under the Supervisor Controls panel to its off position and the PW Monitor is ready to monitor the loading of the press

Computer Input Plug



Wire colors may vary.

Figure 19

Computer to Monitor Addresses

Each Monitor connected to a computer must have a its own unique address. To set the address for a unit, remove the supervisor panel on the door of the enclosure to access the processor circuit board. Switches 1-6 of DIP-switch SW313 each has a numeric value assigned to it. The Address of the unit is the sum of all the switches that are turned “on”.

Figure 20 below is a portion of the label attached to the underside of the supervisor’s panel, highlighting the DIP-switch involved.

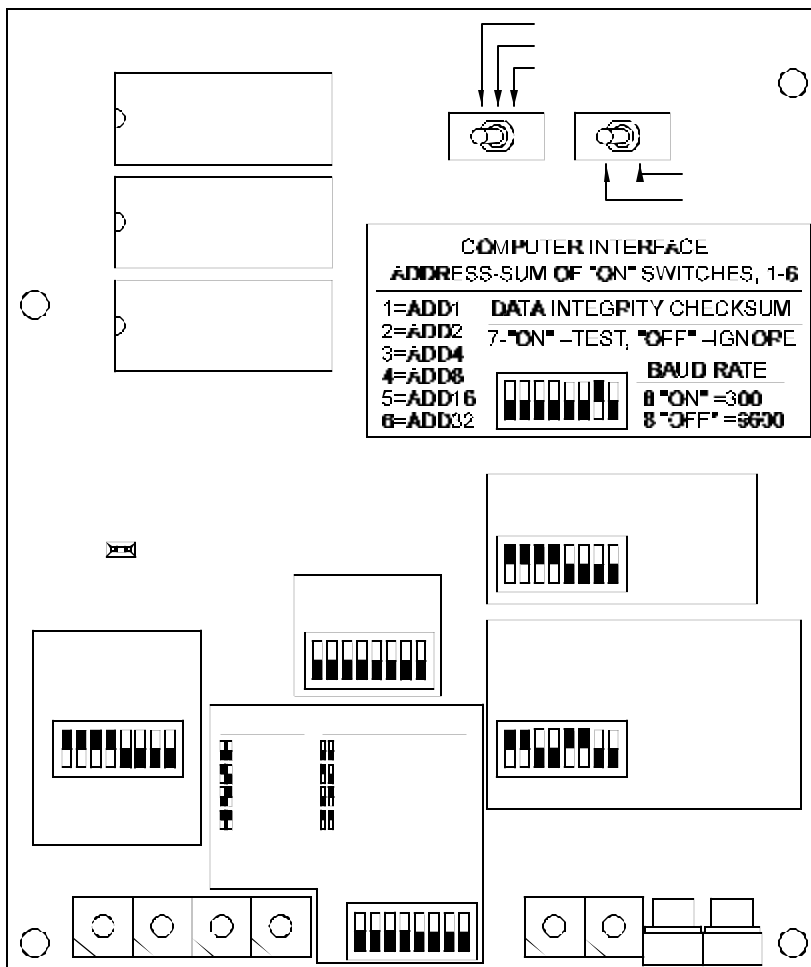

Examples of Address switch settings:

All switches “off” = 0

Switches 1 & 4 “on” = 9

Switches 3 & 5 “on” = 20

Switches 1, 2 & 6 “on” = 35

Figure 20

Connections from Computer to Single Monitor

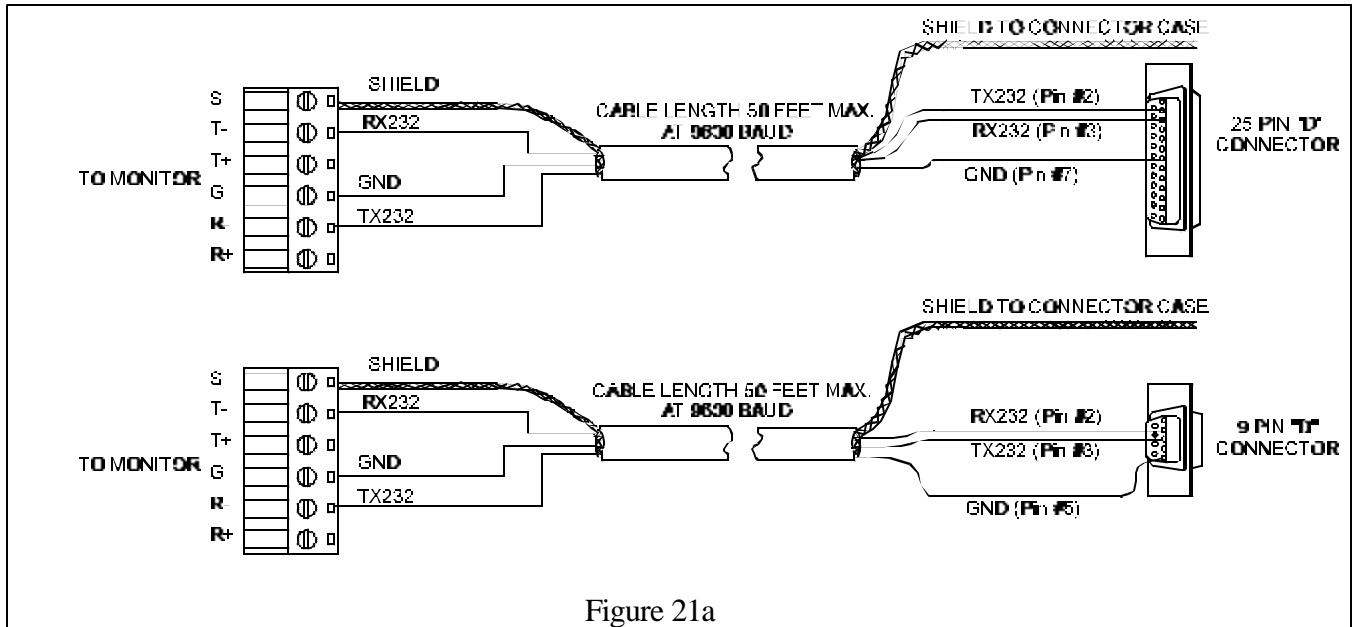

Figure 21a

Connections from Computer to Multiple Monitors Plant Wide

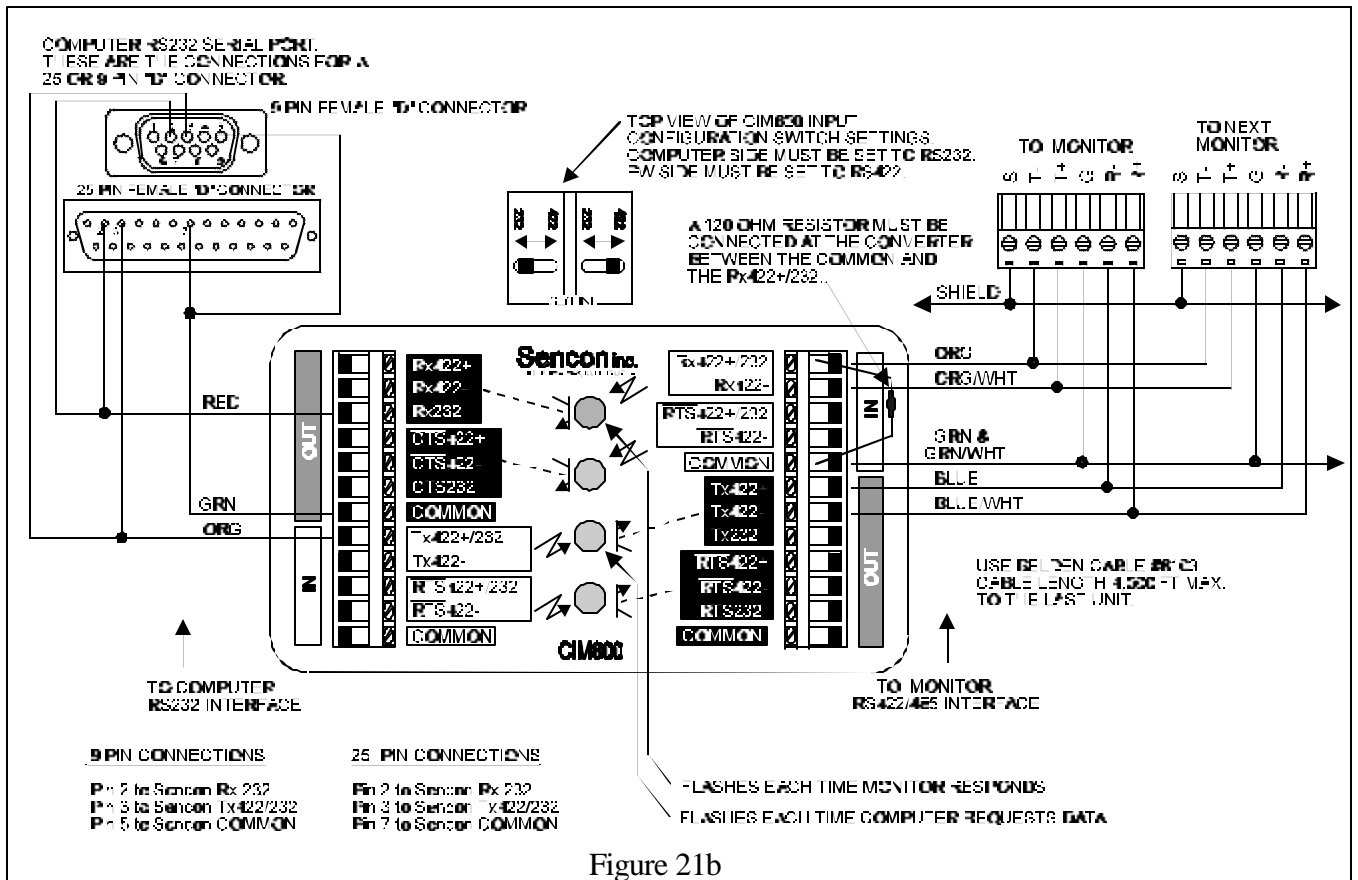

Figure 21b

Introduction to the PW Series Calibration

The Calibration manual is the second part of the full PW manual that includes the Installation and Operation manuals.

It will assist you in all the steps towards calibrating your PW.

For further assistance please contact the Toledo Transducers Inc. Technical Service Department at 1-800-T-TOLEDO.

Calibration Procedure

Record All Serial Numbers

Record all serial numbers on the calibration sheet which can be found at the end of this section. These include:

- Press Serial Number
- Monitor Serial Number
- Sensor Serial Numbers
- Auto Cell Serial Numbers

Tighten All Sensors

Check the torque and the location of each sensor. See “INSTALLING T400 TONNAGE SENSORS” at the back of this manual for more details.

2 Channel Monitor

LEFT is channel 1

RIGHT is channel 2

4 Channel Monitor

LEFT REAR is channel 1

RIGHT REAR is channel 2

LEFT FRONT is channel 3

RIGHT FRONT is channel 4

Check Sensor Shields

Make certain all sensor cable shields are fitted properly. The shields must make a good connection with the spade lug. See figure 22.

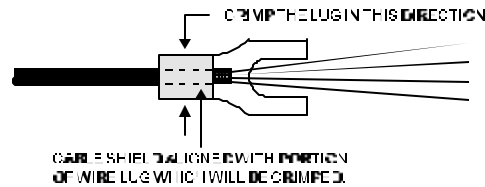

Figure 22

Remove The Cover From The Processor Circuit Board And The Large Panel Covering The Analog And The Power-I/O Circuit Board.

Note: For routine calibrations it is NOT necessary to remove the cover from the CONTROL printed circuit board.

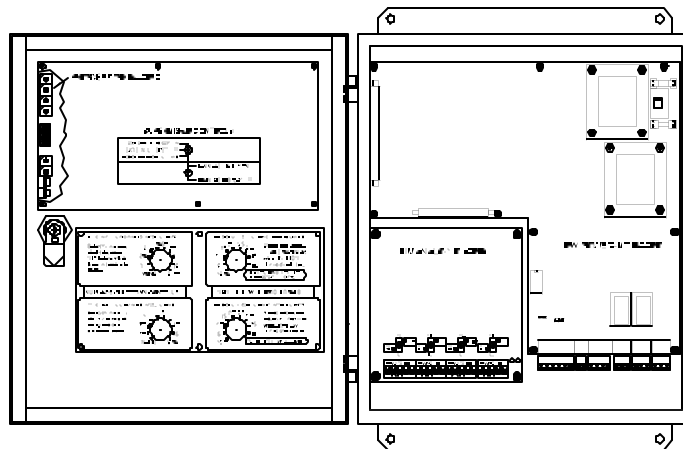

Figure 23

Steps For Calibrating

1. Set press capacity into the monitor

Press capacity is the tonnage rating of the press. The capacity value must be set into the monitor before the calibration can be done. Locate the four small rotary switches on the PW PROCESSOR circuit board. They are at the upper left corner of the circuit board. They are called the CAPACITY switches. Below the switches is an 8-positions DIP switch SW305. Positions 1 and 2 of the DIP switch control the position of the decimal point in the green TONS displays.

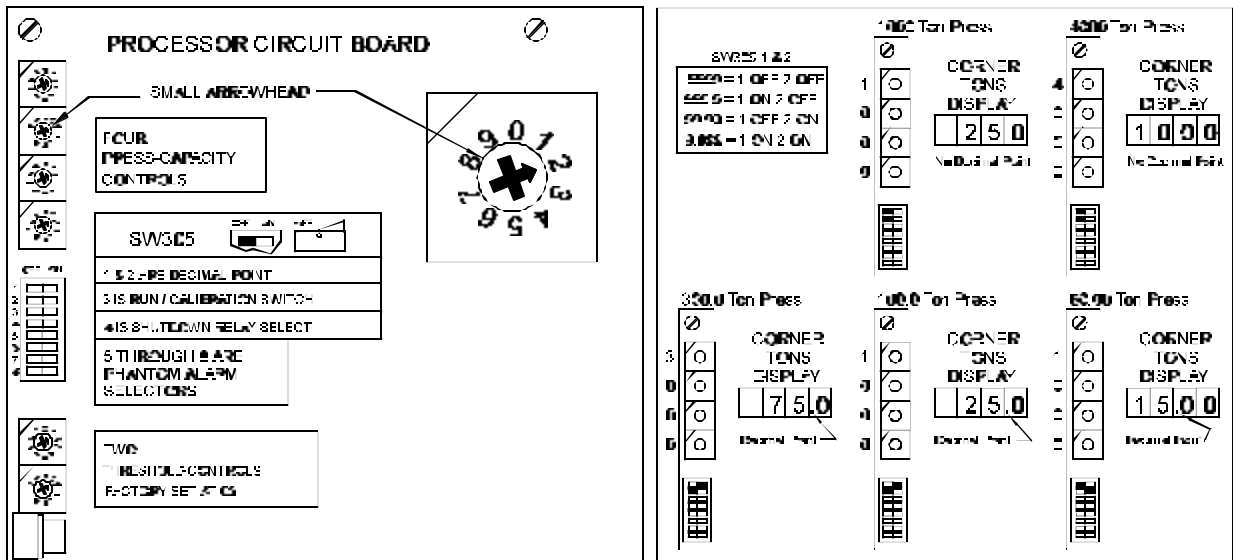

Figure 24

Using various combinations of settings, a variety of tonnages may be adjusted into the monitor. Figure 24 above shows typical examples. A decimal point must be used with press capacities 300 tons or less.

2. Find the shut height of press

Jog the press until the ram is at bottom dead center (BDC), or 180 degrees without any Auto Cells or the die in the press. Determine the amount of spacers needed with your Auto Cells. Use cardboard cushions on top and bottom of the Auto Cells.

3. Place the cells equally at the corners or sides of the press.

4. Cycle press and impact the load cells

Lower the ram (before each cycle) in small increments until full rated tonnage is equally distributed on the Auto Cells. Each cell should read 25% of capacity (with 4 cells) or

50% of capacity (with 2 cells). It should be a balanced load; the readings on each cell should be within 10% of each other.

5. Enable external reset push-button

Open the PW door and make certain the EXTERNAL RESET switch is in the ON (up) position.

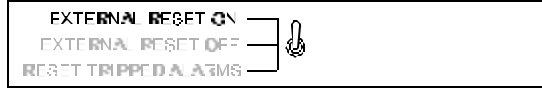

Figure 25

6. Put the monitor in calibration mode

Locate the DIP switch SW305 on the PROCESSOR circuit board. Put switch # 3 to the ON (right) position. This is the CALIBRATION mode.

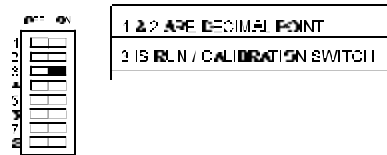

Figure 26

7. Adjust zero-balance of the sensors

Locate the four zero balance controls on the PW Analog circuit board (see next page also). The balance controls are 20-turn screwdriver adjustments (marked B) to the right of the HI/LO switch. Turn the LEFT REAR B control until the LEFT REAR red PERCENT display shows zero:

Note: If a zero value cannot be reached, check the resistance of the LEFT REAR sensor. There should be extremely high, (infinite) resistance between any wire and the shield.

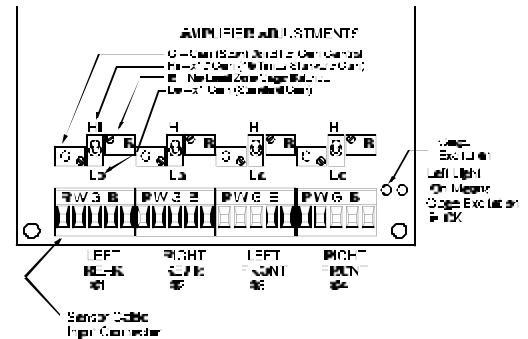

Figure 27

The following are typical nominal sensor resistances:

BLACK to GREEN	350 ohms
GREEN to RED	260 ohms
BLACK to RED	260 ohms
GREEN to WHITE	260 ohms
BLACK to WHITE	260 ohms
RED to WHITE	350 ohms

8. Repeat the previous step for all of the sensor controls

9. Put monitor back into RUN mode

On the PROCESSOR circuit board, put the DIP switch 305, position 3, to the OFF position (to the left). Turn the function selector switch on the front of the monitor to MANUAL mode.

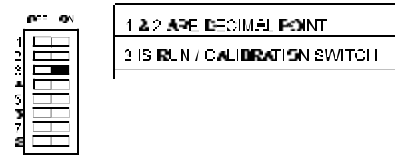

Figure 28

10. Adjust instrument span (gain)

Locate the instrument span controls on the PW ANALOG board. These are the 20-turn screwdriver adjustments marked G (meaning GAIN or span) located to the left of the HI/LO toggle switch.

Cycle the press at full capacity. Read the LEFT REAR tonnage from the Auto Cell. Check the PW monitor LEFT REAR display and adjust the LEFT REAR span control (G-GAIN control) accordingly, up or down. Cycle the press again and repeat this process until the readings match. It may take several press cycles until the readings match.

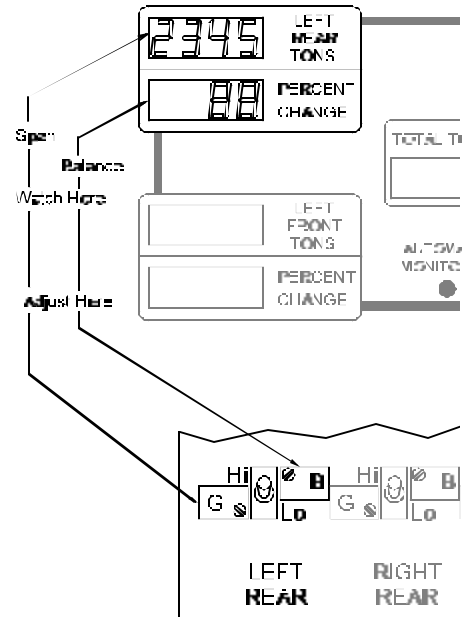

Figure 29

11. Repeat the previous step for the right rear, left front and right front controls.

12. Record the calibration numbers

Push the CHECK CALIBRATION button on the front of the monitor. The calibration numbers will be shown in the green displays. Write them on the calibration label. Also, record the appropriate DIP switch SW305 settings on the instrument label and the calibration sheet.

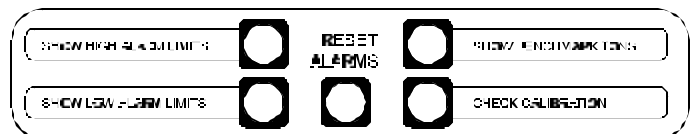

Figure 30

13. Make linearity check

Raise the shut-height in .020 to .030 inch increments and impact on the Auto Cells.
Compare the tonnage applied to the Auto Cells to the tonnage displayed by the monitor.
Record these values for comparison on the CAL sheet.

14. Check to make certain that alarms stop the press

Locate the BYPASS toggle switch near the lower right corner of the IN/OUT circuit board. For the monitor to stop the press when an alarm trips, the toggle switch must be in the down positions. To prevent an alarm from stopping the press, the switch must be in the up (bypass) position.

Put the BYPASS switch in the up (bypassed) position. Notice that all front panel displays are turned off. The monitor still has power and is turned on but is not operational. However, the benchmark tonnage and any information stored in memory is retained.

Put the BYPASS switch in the down (not-bypassed) position. In this position the alarms are active and capable of stopping the press if the monitor is connected into its stop circuits. Push and release the RESET button on the front of the monitor. Cycle the press and create a small overload condition. The press should stop at the top of the stroke.

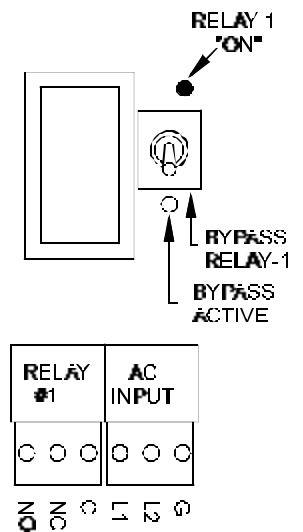

Figure 31

15. Calibration is completed. Replace all panels.

This is necessary for noise protection.

Introduction to the PW Series Operations

The Operating manual is the third part of the full PW manual, which includes the Installation and Calibration manuals.

The PW Series Operating Manual covers all operations of the PW2, PW4, PW2 PLUS and PW4 PLUS monitors.

The operations for the two channel and four channel are the same.

Differences between the PW and PW PLUS are recognized throughout this section of the manual.

For further assistance please contact the Toledo Transducers Inc. Technical Service Department at 1-800-T-TOLEDO.

Chapter One: Using the Outside Controls

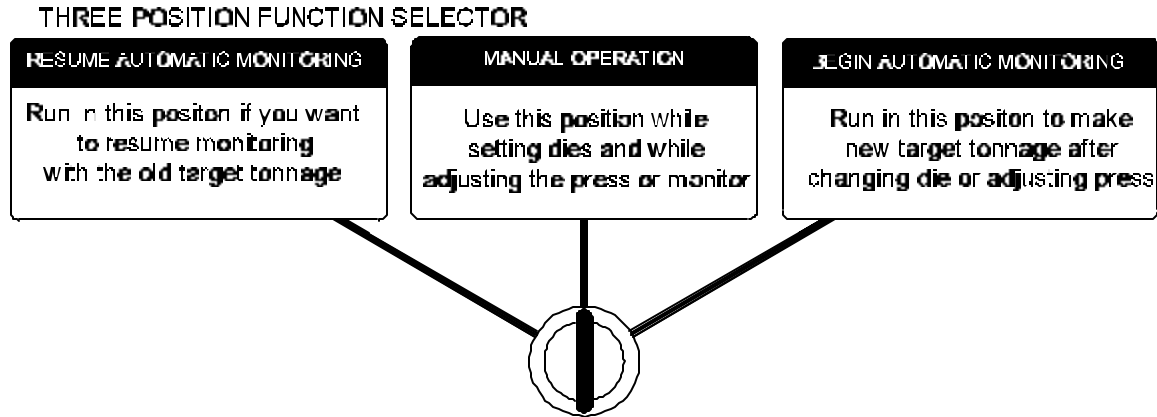
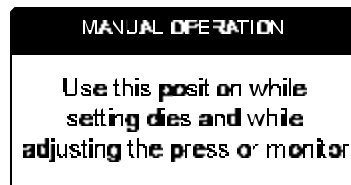

Figure 32: Function Selector



Resume Automatic Monitoring

This left position is used if you want to continue monitoring with the prior target tonnage.



Manual Operation

This middle position is used if you are setting dies while adjusting the press or monitor.

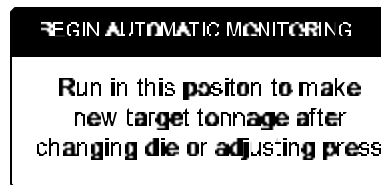

Begin Automatic Monitoring

This right position is used if you want to make a new target tonnage after changing a die or adjusting a press.

Pushbutton Selectors

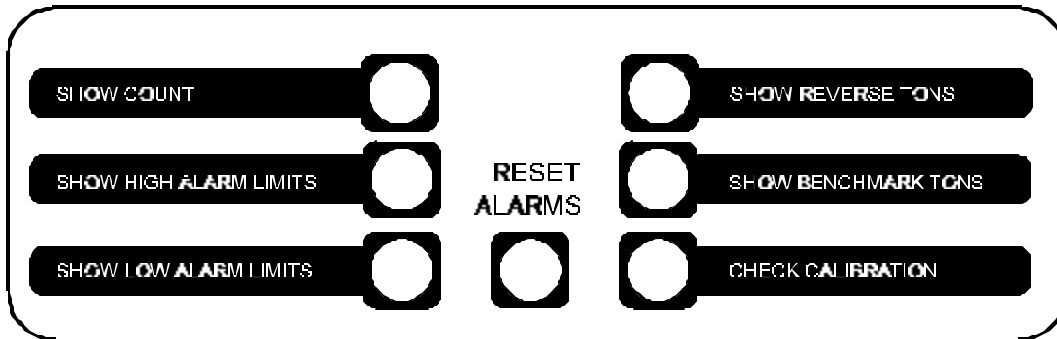

Figure 33



Reset Alarms

Press this button to reset any tripped alarms. It may be disabled from the SUPERVISOR CONTROLS on the inside panel (See Page 35). Pressing Reset in the Begin Automatic Monitoring mode can stop the press.



Show High Alarm Limits

Press this button to view the high limits in tons and percentage of tons.



Show Low Alarm Limits

Press this button to view the low limits in tons and percentage of tons.



Show Benchmark Tons

Press this button to view stored benchmark (target) tons for each corner of the press.



Check Calibration

Press this button to view the PW's calibration numbers and check the accuracy of the monitor.

Pushbutton Selectors cont.



Show Count (PW PLUS Only)

Press this button to view the current part/press strokes count. It will NOT count in Manual Position.



Show Reverse Tons (PW PLUS Only)

Press this button to view the snap-through or reverse tons generated during the press stroke.

Signal Output (Access to a strip chart recorder or scope)

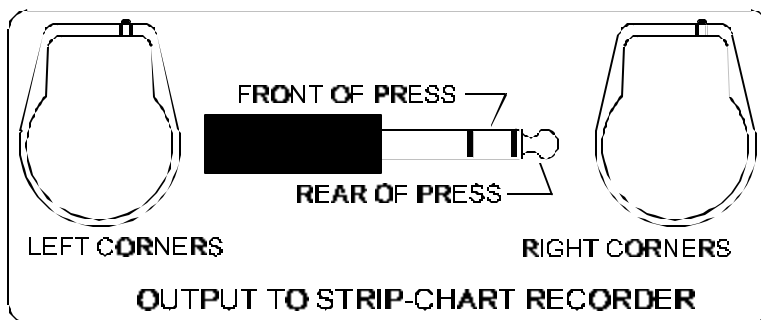

Figure 34

An oscilloscope or strip-chart recorder may be plugged into the left and right signal jacks to retrieve an analog track signal. This signal is used to analyze changes in the press frame and problems with the press or die. 2.5VDC is equal to the capacity shown in that specific channel. For example, if you are reading tonnage on a 400 ton press, on a four channel unit, the capacity in each channel equals 100 tons. When looking at the output, 2.5V would equal 100 tons. 1.25V would equal 50 tons.

Chapter Two: Alarms and Flashing Displays

Alarms

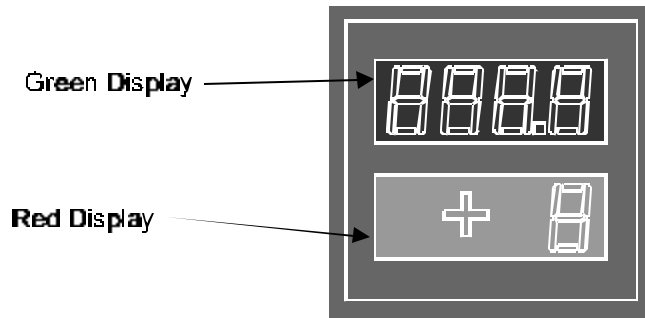

Figure 35

Capacity Alarms

Green and Red Alternating (Green, Red, Green, Red etc.)

These alarms will trip if any press corner exceeds the capacity of the press.
The capacity limits may be displayed by pressing and holding RESET ALARMS.

High and Low Alarms

Red Display Only

These alarms will trip if the tonnage exceeds the pre-selected settings in the ALARM CONTROL panel (See Pages 37 - 40).
High and Low alarm limits are set automatically when you use BEGIN or RESUME AUTOMATIC MONITORING.

Phantom Alarms (PW Only)

Green and Red Displays Together

These alarms are used only if Nuisance controls are functional (See Page 37).
The alarm limits are set between Auto-Set alarm limits and Maximum Tonnage Alarm limits.

Drift Control Alarms (PW PLUS Only)

These alarms control tonnage deviation from press stroke to press stroke.
The press will stop if the tonnage has extreme percentage out of the High or LOW limits.
Drift Control Alarm limits are set automatically with High and Low limits.

Chapter Three: Inside Controls

Supervisor Controls

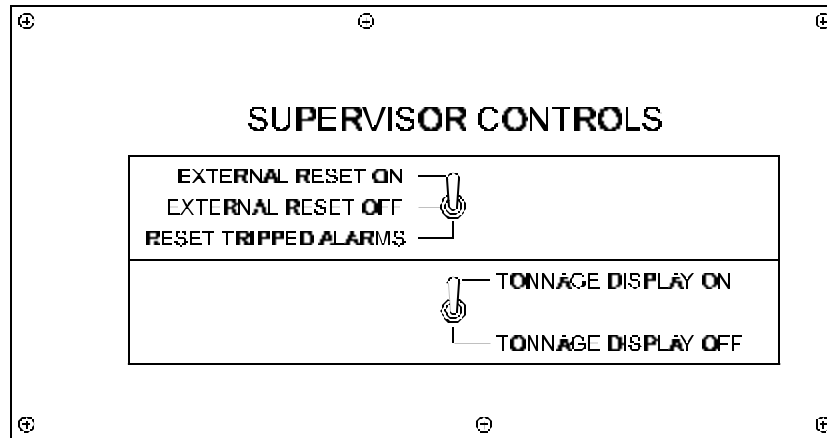
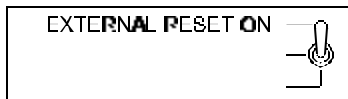

Figure 36



External Reset On

Toggle the top switch up to turn the outside panel RESET ALARMS button on.



External Reset Off

Toggle the top switch to the middle position to turn the outside panel RESET ALARMS button off.



Reset Tripped Alarms

If you choose to turn the outside panel RESET ALARMS button off (in the previous step) toggle the top switch down to reset alarms. (The toggle will reset to the middle.)

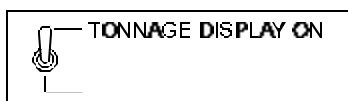

Tonnage Display On

Toggle the bottom switch up to turn the outside Green Displays on.



Tonnage Display Off

Toggle the bottom switch down to turn the outside Green Displays off, only in Automatic Mode.

Nuisance Controls (Regular PW Only) (If you have a PW PLUS, see the next page)

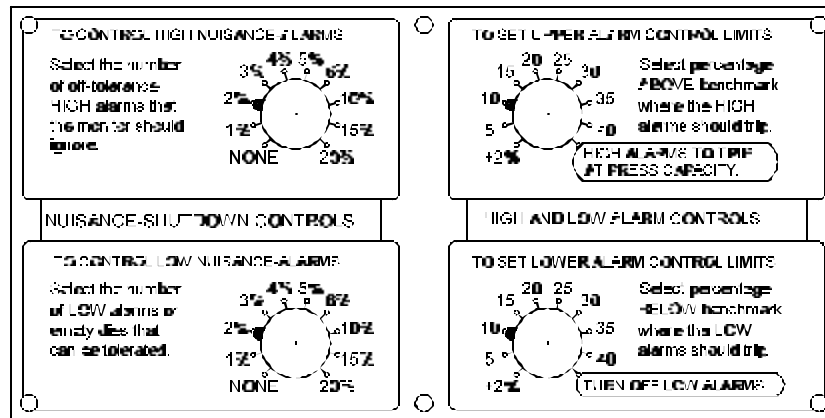
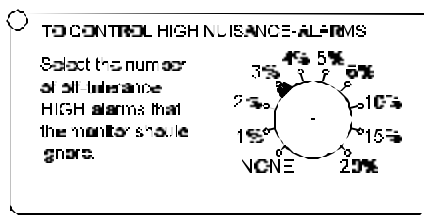
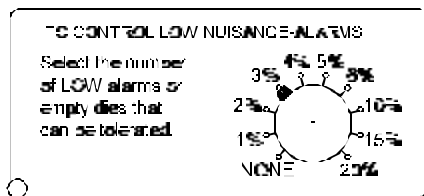

Figure 37



High Nuisance Alarms

Set this to the percentage of high alarms you want to ignore out of 100 strokes: Set to 3% and the PW will ignore 3 alarms out of 100.



Low Nuisance Alarms

Set this to the percentage of low alarms you want to ignore out of 100 strokes: Set to 3% and the PW will ignore 3 alarms out of 100.

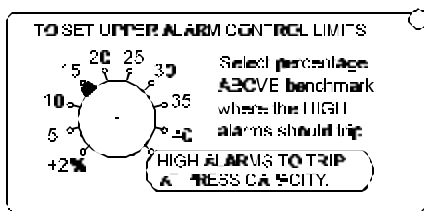

High Alarms

Set this to the percentage above or at the benchmark (target tonnage) where you want the high alarms to trip: Set to 15 and the PW will ignore 15% more tonnage than the benchmark. High alarms can be set to capacity.

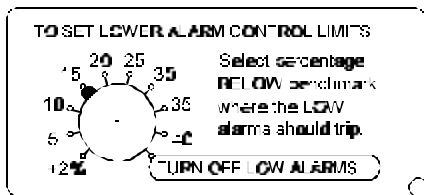

Low Alarms

Set this to the percentage below the benchmark (target tonnage) where you want the low alarms to trip: Set to 15 and the PW will ignore 15% less tonnage than the benchmark. Low alarms can be turned off.

PW PLUS Controls

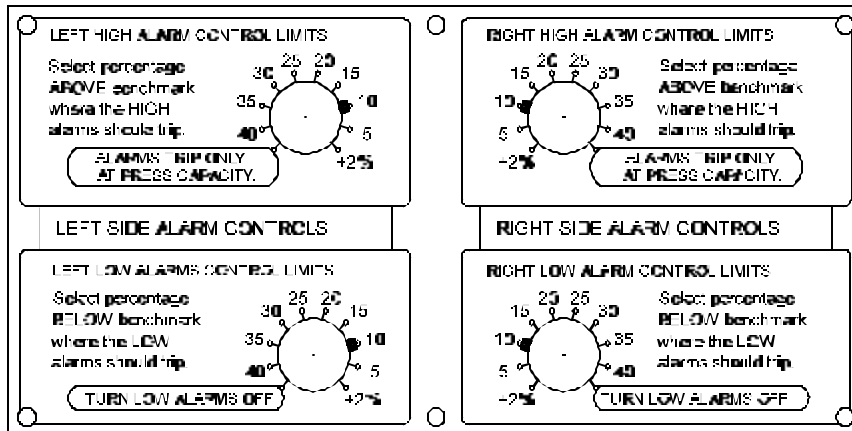
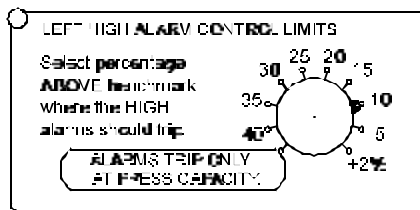
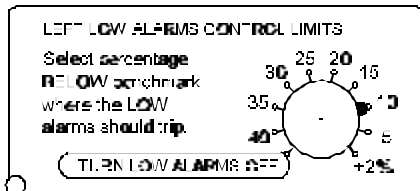

Figure 38



Left High Alarm Controls Limits

Set this to the percentage above or at the benchmark (target tonnage) where you want the left side high alarms to trip. Set to 10 and the PW PLUS will ignore 10% more tonnage than the benchmark. Left High alarms can be set to capacity.



Left Low Alarm Controls Limits

Set this to the percentage below the benchmark (target tonnage) where you want the left side low alarms to trip. Set to 10 and the PW PLUS will ignore 10% less tonnage than the benchmark. Left Low alarms can be turned off.

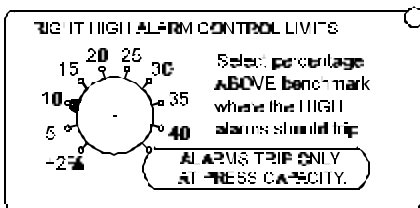

Right High Alarm Controls Limits

Set this to the percentage above or at the benchmark (target tonnage) where you want the right side high alarms to trip. Set to 10 and the PW PLUS will ignore 10% more tonnage than the benchmark. Right High alarms can be set to capacity.



Right Low Alarm Controls Limits

Set this to the percentage below the benchmark (target tonnage) where you want the right side low alarms to trip. Set to 10 and the PW PLUS will ignore 10% less tonnage than the benchmark. Right Low alarms can be turned off.

OPTIONAL Automatic Target Tonnage Recall Controls (PW PLUS Only)

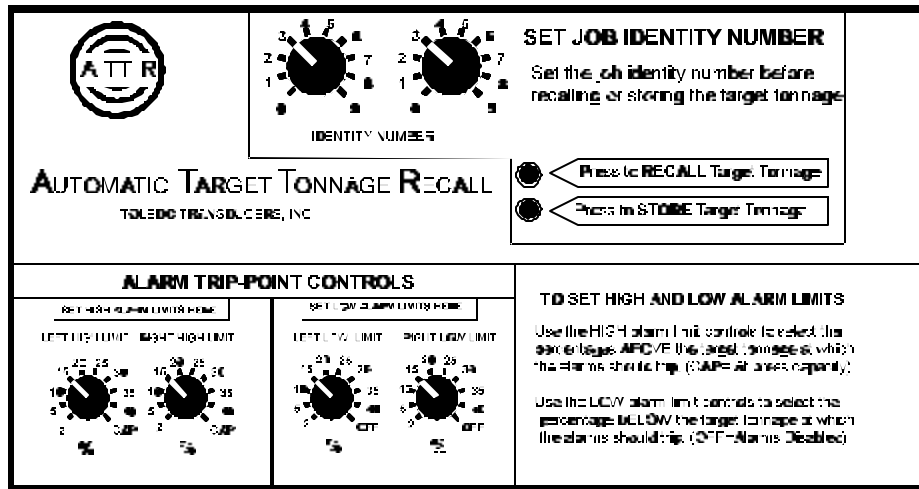
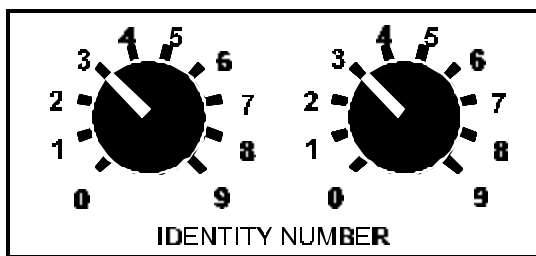

Figure 39

Automatic Target Tons Recall retrieves the ideal benchmark, working tonnage and high and low alarm limits, as a percentage and tonnage for up to 100 jobs.

ATTR stores the ideal working tonnage and alarm control limits, the setup time can be decreased the next time that job is run.

Storing a Job



1. Assign an arbitrary two-digit job number to the job currently being run.
2. Enter the Job Identity Number on the two dials.



3. Push the STORE button.

Automatic Target Tonnage Recall Controls Continued

Recalling a Job

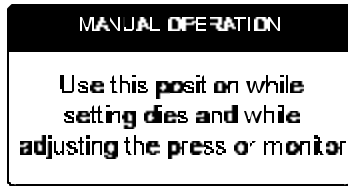

1. Put the PW into Manual Operation on the front door panel.

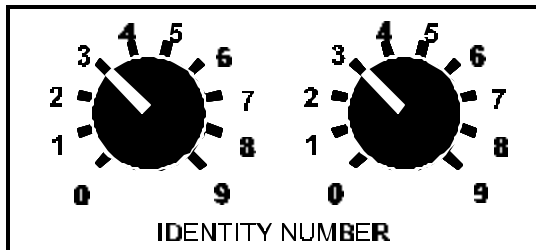

2. Enter the Job Identity Number on the two dials.

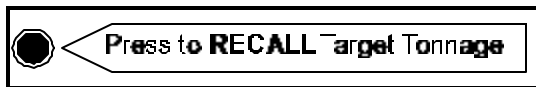

3. Push the RECALL button.

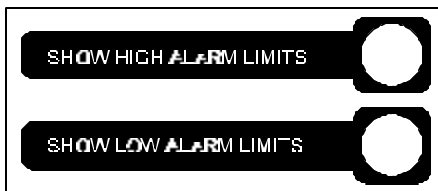

4. Push Show High or Low Limits to view the recalled Alarm limits.

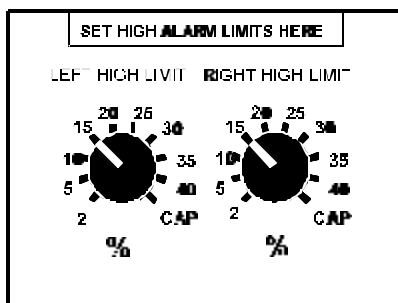

High Alarms

Set this to the percentage above the benchmark (target tonnage) where you want the high alarms to trip: Set to 15 and the PW will ignore 15% more tonnage than set capacity for each side of the press. High Alarms can be set at capacity.

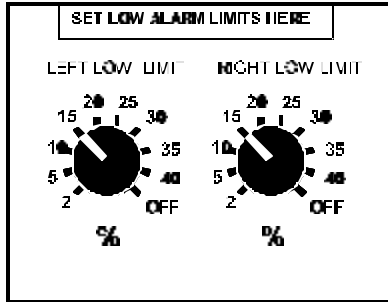

Low Alarms

Set this to the percentage below the benchmark (target tonnage) where you want the low alarms to trip: Set to 15 and the PW will ignore 15% less tonnage than set capacity for each side of the press. Low alarms can be turned off.

Addendum

T400 Installation

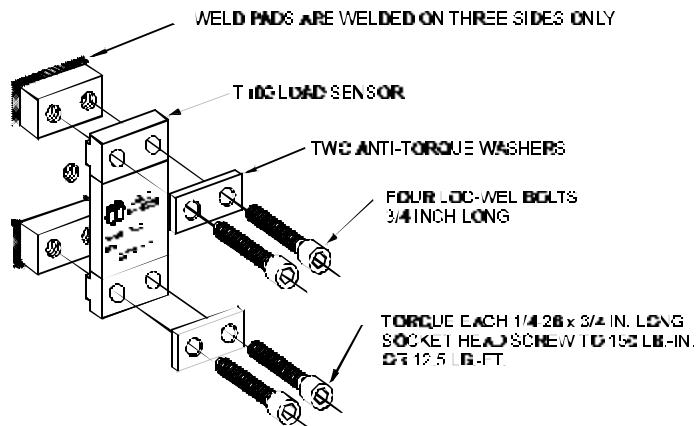
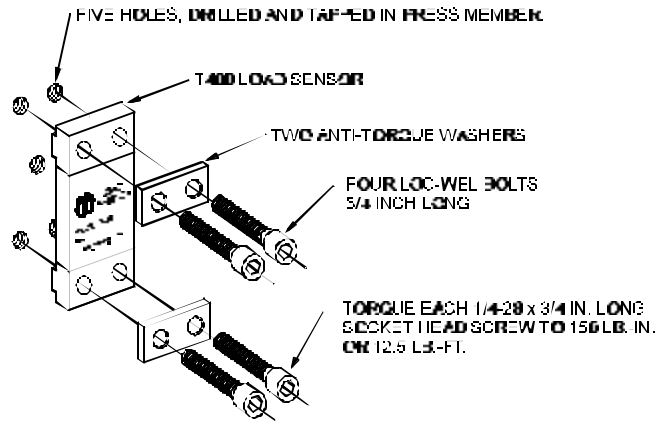

The above illustrations represent the proper arrangement of Model T400 Load Sensor kit parts using either the Drill and Tap method or the Weld method.

A proper installation is necessary to produce good results.

Before installing the sensors, please read the appropriate instructions listed below.

Sensor Placement	Page 42
Press Frame	Page 43
Pitman Mount	Page 44
Drill and Tap Method of Installing Sensors	Page 45
Weld Method of Installing Sensors	Page 46
T400 Enclosure Mounting Details	Page 47

NOTES:

- 1) (2) SENSORS REQUIRED
- 2) (2) SENSOR ENCLOSURES ARE INCLUDED. THESE HELP PROTECT THE T400 SENSOR GAUGES. THESE ENCLOSURES INCLUDE 1/2" KNOCK-OUT HOLES. IF CONDUIT IS USED, WE SUGGEST USING 1/2" STRAIN RELIEFS IN THE KNOCK-OUT HOLES.

SENSOR PLACEMENT

Sensor location must be determined. You have two locations. The front or the rear of the press. (Shown in the shaded area.)

HOW TO DETERMINE THE BEST LOCATION

* MEASURE THE REAR THICKNESS _____ REAR

* MULTIPLY BY THREE X 3 =

* MEASURE THE FRONT THICKNESS _____ FRONT

If the front thickness is smaller than value in , then mount sensors in the front. (This is the most common.) If the front thickness is larger, then place the sensor in the rear. Adjust the input connection for compression readings instead of tension.

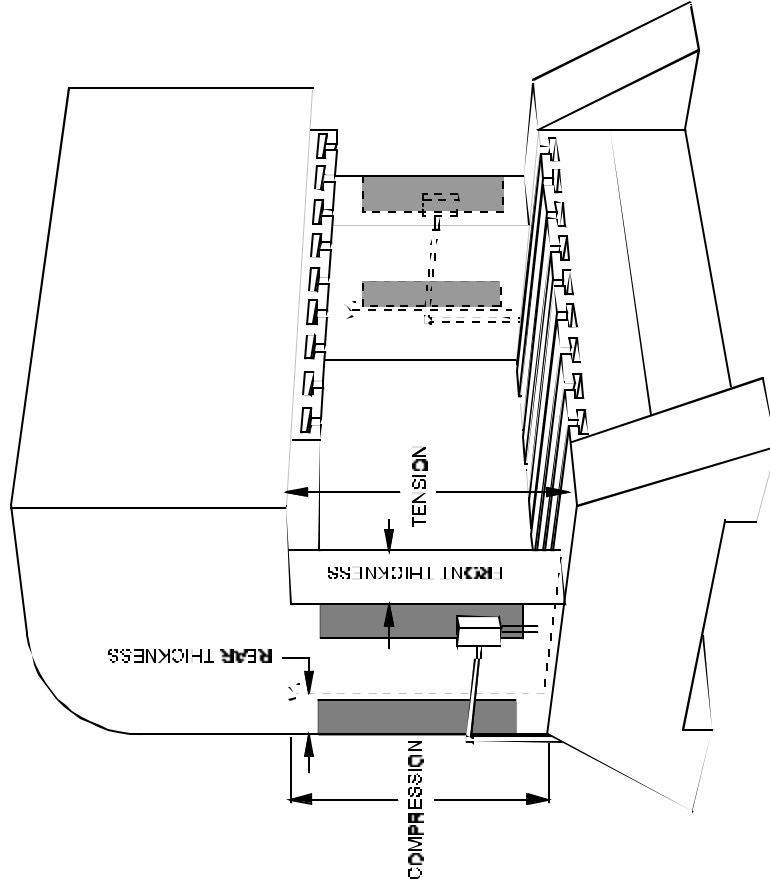

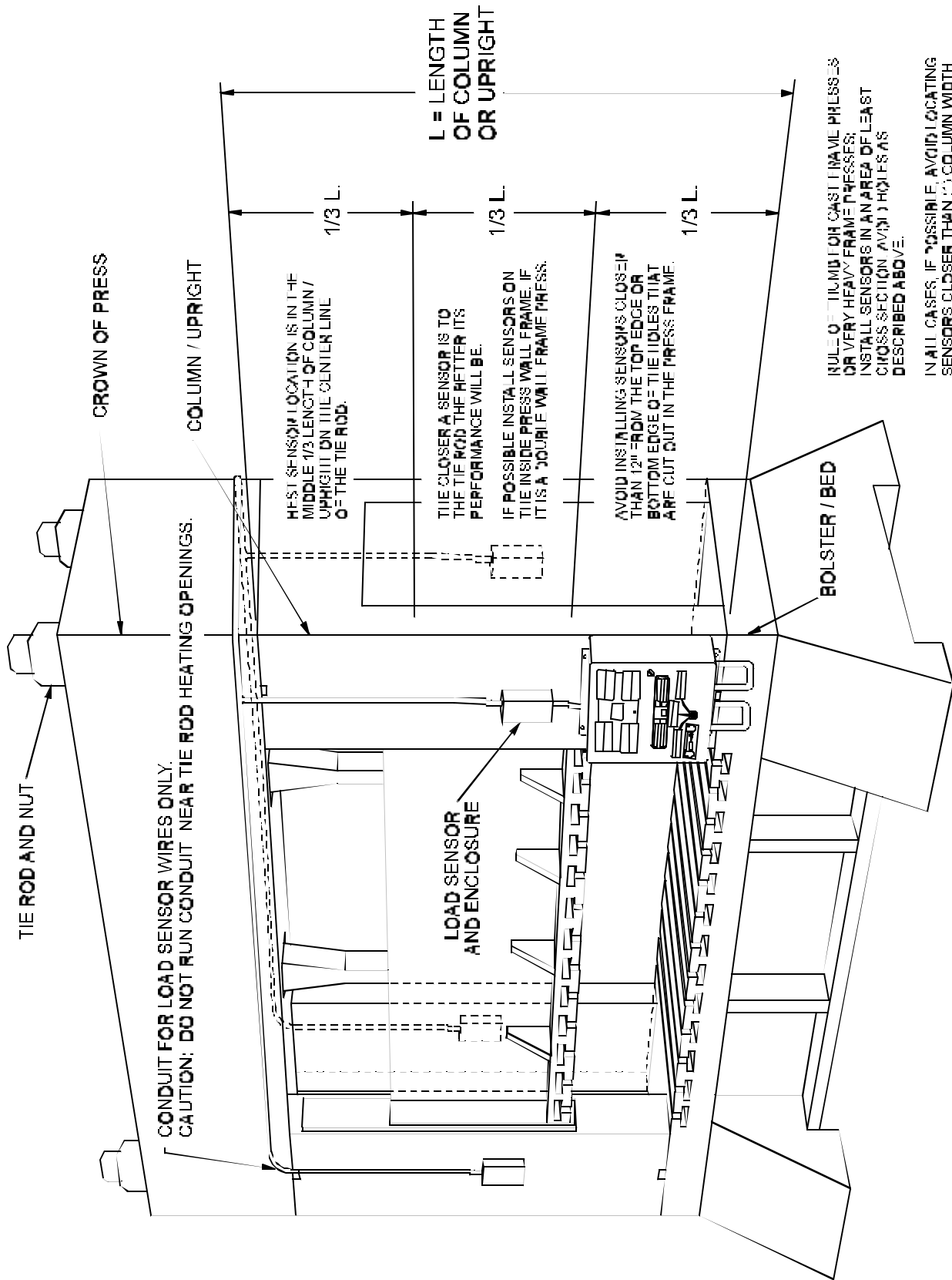

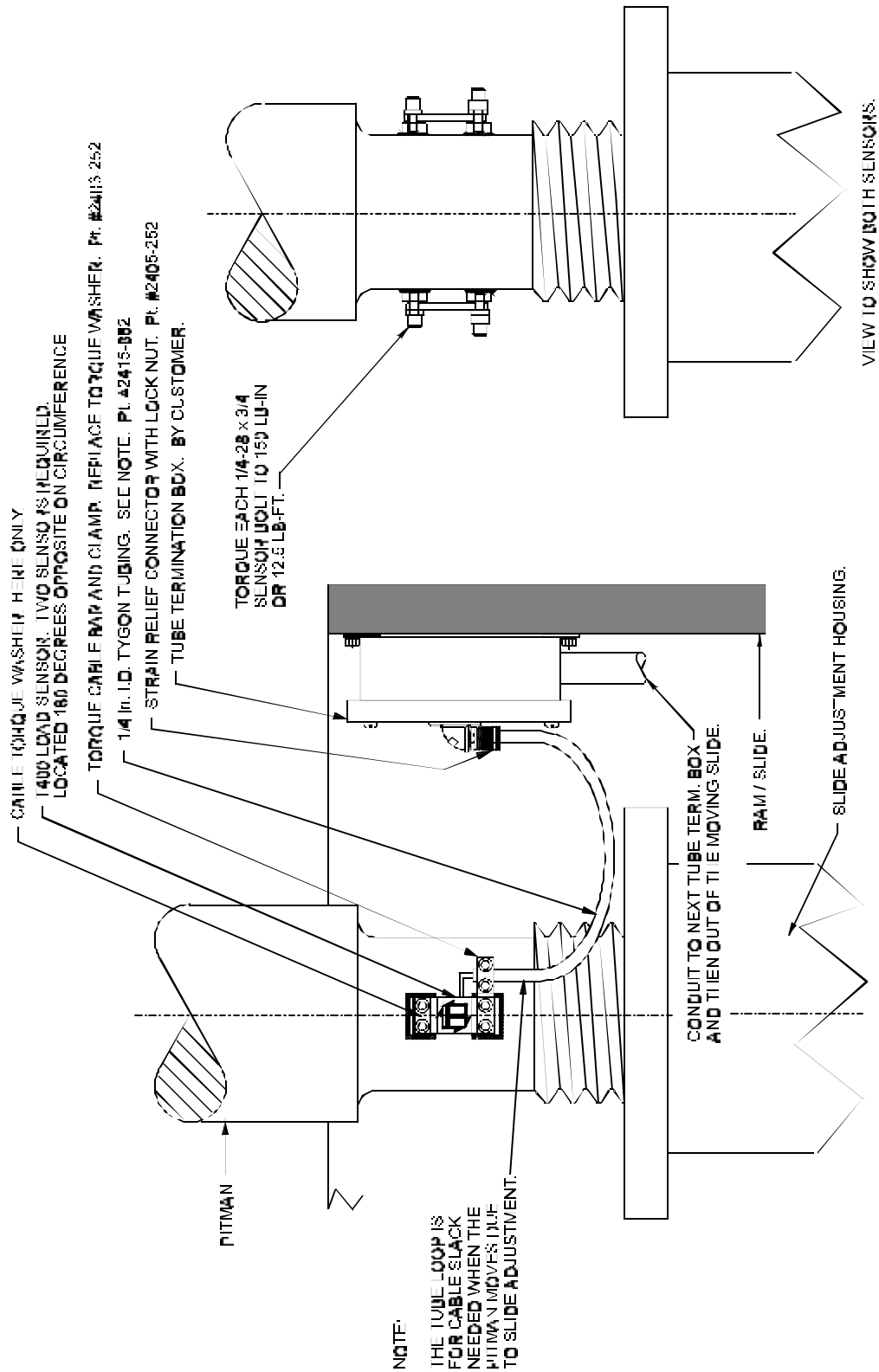

USING THE T400 SENSOR INSTALLATION FIXTURE KIT No. 1977-749

(METRIC INSTALLATION FIXTURE KIT No. 1974-749)

DRILL AND TAP METHOD FOR MOUNTING SENSORS

BE SURE THE SENSOR LOCATION FOLLOWS THE BEST LOCATION DESCRIBED ON THE PREVIOUS PAGES.

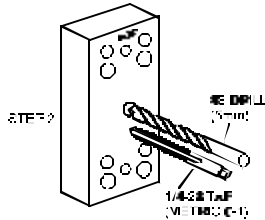

STEP 1 Remove all paint and grease from sensor mount area. If the machine surface is flat (total indicated reading of .002") and smooth (125 μ in.) the load sensor can be bolted directly to the surface.

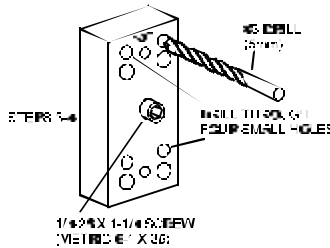

STEP 2 Drill and tap the center hole for mounting the fixture to the press member. This hole should be 1/2 inch (13mm) deep.

STEP 3 Bolt the fixture to the press member using the 1/4-28 by 1-1/4 inch (M6-1 x 35) long socket head cap screw in the center of the fixture.

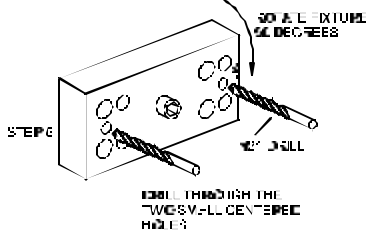

STEP 4 Insert the number 3 drill (5mm) into the smaller corner hole and drill out all four holes to a depth of 3/4 of an inch (19mm.)

STEP 5 Loosen the fixture. Rotate the fixture 90 degrees clockwise. Tighten the center screw of the fixture. Insert the number 21 drill into the small centered hole and drill out both holes to a depth of 3/8 of an inch. These holes are for mounting the sensor enclosure. The fixture does not allow for tapping these holes. They are tapped without the fixture. Enclosure mounting is not done in metric.

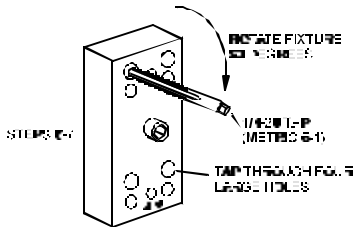

STEP 6 Loosen the fixture. Rotate the fixture another 90 degrees clockwise such that the larger corner holes line up with the holes drilled in Step 4. Insert a tap to be sure the holes line up. Lock the fixture in place by tightening the center screw.

STEP 7 Insert the tap into the larger tap guide holes and tap each hole.

BE SURE TO USE PLENTY OF TAPPING FLUID.

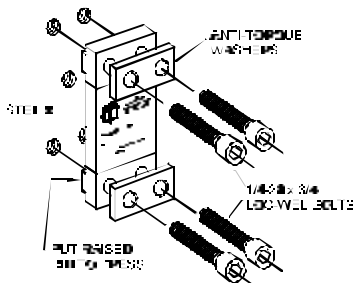

STEP 8 Remove the fixture and repeat Steps 1-7 for each additional sensor mounting position.

STEP 9 Mount the sensor with the raised rib to the press. The anti-torque washers should go between the screw and the sensor body. Torque each 1/4-28 x 3/4 in. long socket head cap screw to 150 LB.-IN or 12.5 LB.-FT.

USING THE T400 SENSOR INSTALLATION FIXTURE KIT No. 1977-749

WELD PAD METHOD FOR MOUNTING SENSORS

BE SURE THE SENSOR LOCATION FOLLOWS THE BEST LOCATION DESCRIBED ON THE PREVIOUS PAGES.

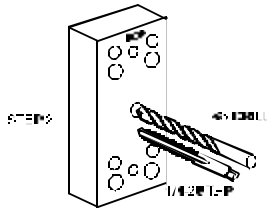

STEP 1 Remove all paint, grease, and or rust from surface to be welded. (Surface should be flat T.I.R. 1/32 of an inch.)

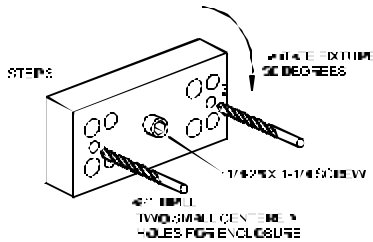

STEP 2 Drill and tap the center hole for mounting the fixture to the press member. This hole should be 1/2 inch deep. (Optional)

STEP 3 Bolt the fixture to the press member using the 1/4-28 by 1-1/4 inch long socket head cap screw in the center of the fixture. Orient the fixture as shown and drill out the #21 holes to a depth of 3/8 of an inch for the enclosure mounting. The fixture is not used for tapping these holes. (Optional)

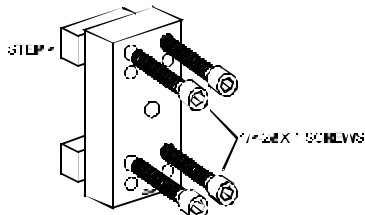

STEP 4 Remove the fixture from the press member. Bolt the weld pads to the fixture with 1/4-28 by 1 inch long socket head cap screws provided. Reattach the fixture with the weld pads bolted on using the center hole as in Step 3. Orient the fixture as shown.

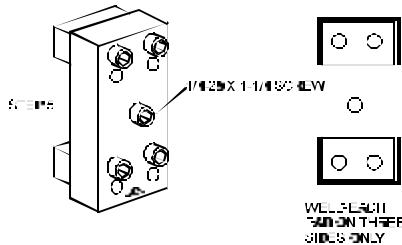

STEP 5 Weld the weld pads to the press member. (BE SURE TO ONLY WELD THE WELD PADS ON THREE SIDES AS SHOWN.) A single pass is sufficient. Do not remove the fixture until slag is removed and or assembly has cooled. When welding cast iron, use a dry nickel rod such as: Lincoln Electric "Soft Weld", Hobart "NI Cast 99", or MB Weld Prod. "MG 210. Strike arc on steel then puddle into the cast iron.

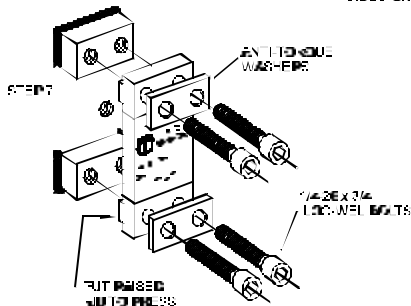

STEP 6 Remove the weld fixture. DO NOT WELD AFTER FIXTURE IS REMOVED. The 4 screws holding the pads to the fixture and the 1 center screw may be discarded. DO NOT USE THE FOUR 1 INCH LONG SCREWS TO ASSEMBLE SENSOR. The sensor kit contains four 3/4 inch long screws for assembling the sensor to the press member. Weld pad surface must be clean – no weld bumps, scratches, etc. Be sure the weld pad tapped holes are clean and bottom of holes are free of weld flash.

STEP 7 Mount the sensor with the raised rib to the press. The anti-torque washers should go between the screw and the sensor body. Torque each 1/4-28 x 3/4 in. long socket head screw to 150 LB.-IN or 12.5 LB.-FT.

SENSOR ENCLOSURE MOUNTING

USE 10-32 TAP IN THE TWO 3/8" DEEP HOLES THAT WERE DRILLED WITH THE FIXTURE IN THE PREVIOUS INSTRUCTIONS. MOUNT THE ENCLOSURE TO THE PRESS MEMBER AND RUN 1/2 INCH CONDUIT TO THE LOAD MONITOR ENCLOSURE.

RUN SENSOR CABLE THROUGH CONDUIT. PLACE SENSOR ON MOUNTING HOLES. PLACE ANTI-TORQUE WASHERS OVER SENSOR HOLES. SCREW IN SENSOR BOLTS, (4) EACH, FINGER TIGHT. USE ONLY THE 1/4-28 x 3/4 100 WELT BOLTS THAT ARE IN THE SENSOR PACKAGE. TORQUE EACH 1/4-28 x 3/4 SCREW TO 150 LB.-IN. OR 12.5 LB.-FT. ASSEMBLE BOX COVER.

