



Toledo Transducers
PLS-801
Programmable Limit Switch System
User's Manual

Rev. 1

TABLE OF CONTENTS

- 1.0 SCOPE.....2**
- 2.0 PROGRAMMABLE LIMIT SWITCH FUNCTIONAL DESCRIPTION2**
- 3.0 PLS-801 SYSTEM COMPONENTS3**
 - 3.1 TRANSDUCER.....3
 - 3.2 PLS-801 CONTROL UNIT.....4
 - 3.2.1 ENCLOSURE.....4
 - 3.2.2 INTEGRAL PROGRAMMER.....4
 - 3.2.3 INTERNAL ELECTRONICS4
 - 3.2.4 AC/DC POWER SYSTEM5
 - 3.2.5 INTERFACE CONNECTORS.....5
 - 3.2.6 PLS-801 OUTPUT BOARD6
 - 3.3 TRANSDUCER/CONTROL UNIT INTERFACE CABLE.....7**
- 4.0 USING THE PLS-8018**
 - 4.1 INSTALLATION.....8**
 - 4.1.1 MOUNTING THE TRANSDUCER8
 - 4.1.2 MOUNTING THE CONTROL UNIT8
 - 4.1.3 CONNECTING THE TRANSDUCER TO THE CONTROL UNIT9
 - 4.1.4 INSTALLING THE AC POWER CORD9
 - 4.1.5 POWERING ON THE CONTROL UNIT9
 - 4.2 PLS-801 PROGRAMMING.....10**
 - 4.2.1 POSITION.....11
 - 4.2.2 SCALE FACTOR.....12
 - 4.2.3 OFFSET.....13
 - 4.2.4 SETPOINT14
 - 4.2.4.A SELECTING THE CHANNEL NUMBER.....15
 - 4.2.4.B DISPLAYING/MODIFYING EXISTING LOBES16
 - 4.2.4.C ENTERING NEW LOBES18
 - 4.2.4.D DELETING EXISTING LOBES.....20
 - 4.2.5 TACHOMETER.....21
 - 4.2.6 MOTION DETECT21
 - 4.3 ERROR CONDITIONS23**
 - 4.3.1 TRANSDUCER SIGNAL ERROR.....23
 - 4.3.2 CONTROL UNIT MICROPROCESSOR FAULT23
 - 4.3.3 LOSS OF AC POWER24

1.0 SCOPE

The purpose of this User's Manual is to describe the operation, installation and programming of the Toledo Transducer's PLS-801 Programmable Limit Switch. It is strongly recommended that this User's Manual be read entirely before placing the PLS-801 into operation. Failure to follow the instructions given in this User's Manual may void your PLS-801 warranty.

Questions regarding any aspect of the PLS-801 should be referred to Toledo Transducers, Inc.:

**Toledo Transducers, Inc.
6834 Spring Valley Drive
Holland, Ohio 43528**

**Phone: (419) 867-4170
Fax: (419) 867-4180**

2.0 PROGRAMMABLE LIMIT SWITCH FUNCTIONAL DESCRIPTION

A wide variety of industrial applications require that an electrical switch be turned 'ON' and 'OFF' at exactly the same point in each cycle of machine operation. The point in the machine cycle that the switch is turned 'ON' is commonly known as the 'TIMING', whereas the length of time that the switch is 'ON' is termed the 'DWELL'.

TIMING and DWELL can be provided by mounting a mechanical cam on a rotating shaft, such that it can make contact with a corresponding electrical switch. The portion of the cam that comes in actual contact with the switch is often known as the 'LOBE'. The design of the cam must allow the user to be able to set both the TIMING and DWELL of the LOBE.

Several cam/switch assemblies can be placed on the same shaft, to provide independent TIMING and DWELL for a number of different machine functions. Each cam/switch assembly is commonly known as a 'CIRCUIT'.

Mechanical cam switches can be very time consuming to set when more than a few circuits are required. In addition, mechanical cam switches are not practical in applications where the switch must be turned 'ON' and 'OFF' a number of times during a single machine cycle ('MULTIPLE LOBES').

A programmable limit switch is a device which overcomes the shortcomings of mechanical cam switches by performing the cam functions electronically rather than mechanically. Instead of having to physically adjust the TIMING and DWELL of a number of mechanical cams, the programmable limit switch ('PLS') allows a user to enter the TIMING and DWELL settings via a keyboard. The TIMING and DWELL settings are then stored in a solid state memory and used to control whether the outputs of the electronic switches are turned 'ON' or 'OFF'.

Because of the relative low cost of today's solid state memories, a PLS can readily accommodate applications requiring a large number of circuits, each with single or multiple LOBES.

3.0 PLS-801 SYSTEM COMPONENTS

The PLS-801 is a state-of-the-art, microprocessor based programmable limit switch that allows a user to easily program single or multiple LOBES for a maximum of 16 independent circuits ('CHANNELS'). In addition, the PLS-801 provides the user with TACHOMETER and MOTION DETECT functions.

The PLS-801 consists of four standard components. These components are an ANGULAR POSITION TRANSDUCER designed to be mounted on the target machine. The CONTROL UNIT that is normally mounted in a NEMA type enclosure. A PROGRAMMER that provides a keyboard/display for data entry and inspection. And an INTERFACE CABLE that connects the TRANSDUCER to the CONTROL UNIT. An optional INTEGRAL RELAY BOARD is available to handle a variety of external AC or DC loads.

The TRANSDUCER, which utilizes a BRUSHLESS RESOLVER, produces an analog signal proportional to the angular position of the machine shaft. This signal is sent to the CONTROL UNIT, where it is converted to digital format and displayed on the PROGRAMMER. During each machine cycle, the CONTROL UNIT will turn the CHANNEL outputs 'ON' and 'OFF' in accordance with the user programmed LOBE data. The CHANNEL outputs can be used directly, or in conjunction with the INTEGRAL SOLID STATE RELAYS.

3.1 TRANSDUCER

The TRANSDUCER is a single-turn rotary position transducer which is used in conjunction with the Control Unit. The TRANSDUCER utilizes a BRUSHLESS RESOLVER which eliminates the reliability problems associated with optical encoders or brush-type resolvers. The brushless resolver is housed in a rugged extruded aluminum enclosure, which is anodized to provide a durable finish. The enclosure is sealed and gasketed to provide oiltight, dust-tight (NEMA 13) protection for the internal electrical components.

A 3/4" inch stainless steel input shaft is used to provide a heavy-duty, corrosion resistant transducer / machine interface. A flexible coupling provides mechanical isolation between the transducer shaft and the resolver for increased mechanical reliability. Sealed ball bearings are used to maximize transducer life, performance, and reliability by providing a high quality bearing for the transducer. The transducer enclosure contains an integral industrial-duty, MS-type connector for interfacing to the Control Unit.

The TRANSDUCER may be mounted via the standard front face mount, or an optional foot mount adapter for retrofit applications.

3.2 PLS-801 CONTROL UNIT

Each CONTROL UNIT consists of an ENCLOSURE, INTERNAL ELECTRONICS, AC/DC POWER SYSTEM and I/O INTERFACE CONNECTORS.

All CONTROL UNITS require a PROGRAMMER for data entry and inspection. A PROGRAMMER consists of four tactile-feel keys and a sixteen character liquid crystal alphanumeric display.

Each CONTROL UNIT is packaged complete with one AC POWER CORD and two MOUNTING BRACKETS.

PLS-801 SPECIFICATIONS

<i>Input Power</i>	115Vac +/- 10% , 1 Phase, 60 hertz
<i>Operating Temperature</i>	32° F to 125° F
<i>Storage Temperature</i>	0° F to 150° F
<i>Maximum Resolution</i>	1000 counts/turn
<i>Standard Scan Time</i>	200 microseconds
.....	(300 rpm at 1000 counts per turn)
<i>Consult factory if lower scan times are required.</i>	
<i>Maximum Number of Lobes</i>	238

3.2.1 ENCLOSURE

The CONTROL UNIT ENCLOSURE is constructed of 14 gauge cold rolled steel, and is designed for easy access should maintenance or repair be required.

3.2.2 INTEGRAL PROGRAMMER

The PLS-801 utilizes an INTEGRAL PROGRAMMER that is permanently attached to the front of the CONTROL UNIT enclosure. A 16-digit alphanumeric liquid crystal (LCD) display is used in conjunction with four tactile-feel keys to allow the user to inspect, enter or modify data. The LCD is also used to display the status of the sixteen Channel output and Motion Detect output.

3.2.3 INTERNAL ELECTRONICS

The CONTROL UNIT is a state-of-the-art, microprocessor based electronic device that features an ULTRA*FAST scan time, as well as high noise immunity. Data is stored in a non-volatile EEPROM memory, that eliminates the need for battery backup. Fault check circuitry has been included to provide a positive indication should the CONTROL UNIT fail to receive a valid signal from the TRANSDUCER, or a microprocessor fault occur. See SECTION 4.3 for a complete description of the Control Unit Error Conditions.

3.2.4 AC/DC POWER SYSTEM

The AC POWER PLUG offers a safe, convenient method of providing AC power to the CONTROL UNIT - eliminating the need to connect individual power wires. An RFI LINE FILTER provides built in protection against RFI (Radio Frequency Interference) induced line noise. An AC POWER FUSE provides electrical protection for the CONTROL UNIT's electronics. The internal DC POWER SUPPLY provides DC power for the CONTROL UNIT.

3.2.5 INTERFACE CONNECTORS

Two interface connectors are supplied on the standard CONTROL UNIT: the TRANSDUCER INTERFACE CONNECTOR and the COMMUNICATIONS OUTPUT CONNECTOR. Both connectors are located on the bottom of the CONTROL UNIT ENCLOSURE, as shown in FIGURE 3.2.5.

The TRANSDUCER INTERFACE CONNECTOR is an eight-pin male connector, used to interface the CONTROL UNIT to the TRANSDUCER. Refer to SECTION 3.3 for complete details on the TRANSDUCER INTERFACE.

The COMMUNICATIONS OUTPUT CONNECTOR is a four-pin male connector, that provides serial data to the remote display. If the CONTROL UNIT is configured for RS232 output, the data can interface to an external computer or PLC.

Both connectors and their pinout definitions are defined in Table 3.2.5

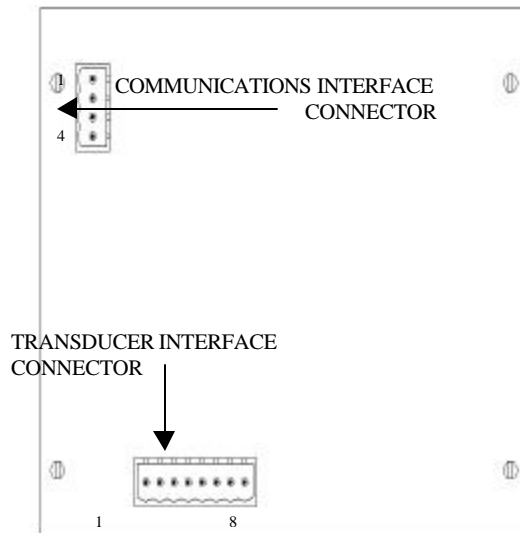

Figure 3.2.5 Bottom view of PLS801

COMMUNICATIONS CONNECTOR		TRANSDUCER INTERFACE CONNECTOR	
Pin 1	GROUND	Pin 1	No connection
Pin 2	RD	Pin 2	No connection
Pin 3	TD	Pin 3	S1 (stator 1)
Pin 4	CTL1	Pin 4	S3 (stator 3)
		Pin 5	S4 (stator 4)
		Pin 6	S2 (stator 2)
		Pin 7	R2 (rotor 2)
		Pin 8	R1 (rotor 1)

Table 3.2.5 Wiring designations for Communications and Transducer Interface connectors

3.2.6 PLS-801 OUTPUT BOARD

The PLS-801 can be interfaced to an external output board that is equipped with either dry contact relays or solid state output modules. The LOBE setpoints stored within the PLS-801 memory will trigger the output board to activate or deactivate the relays or solid state modules as the angular transducer rotates. Figure 3.2.6A illustrates the relay output board and its connection definitions. Both normally closed (NC) and normally open (NO) contacts are available at the output connectors for each channel of this board. Figure 3.2.6B illustrates the solid state output module board and its connection definitions. The outputs of the solid state module are fused with type 2AG, 3.5Amp mini fuses for added protection. The solid state output module board also utilizes on board LEDs to signify the status of each channel. An illuminated LED indicates the channel is active and the associated output module is switched to the ON state.

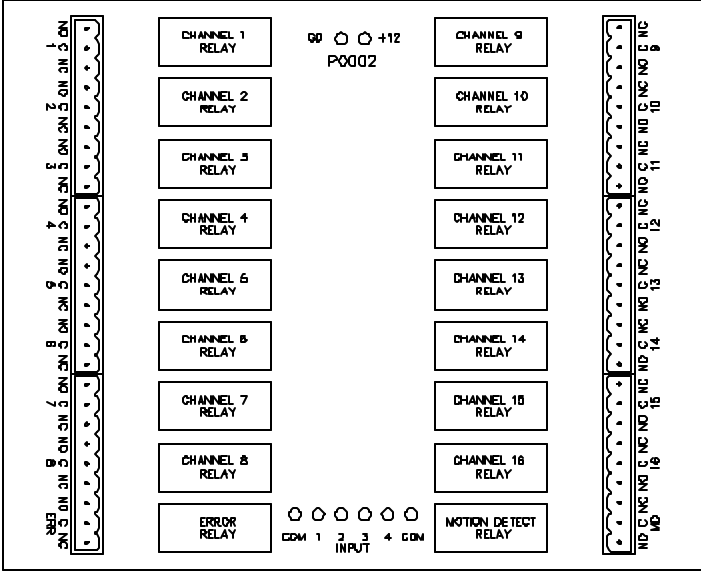

Figure 3.2.6A PLS-801 Relay Output Board

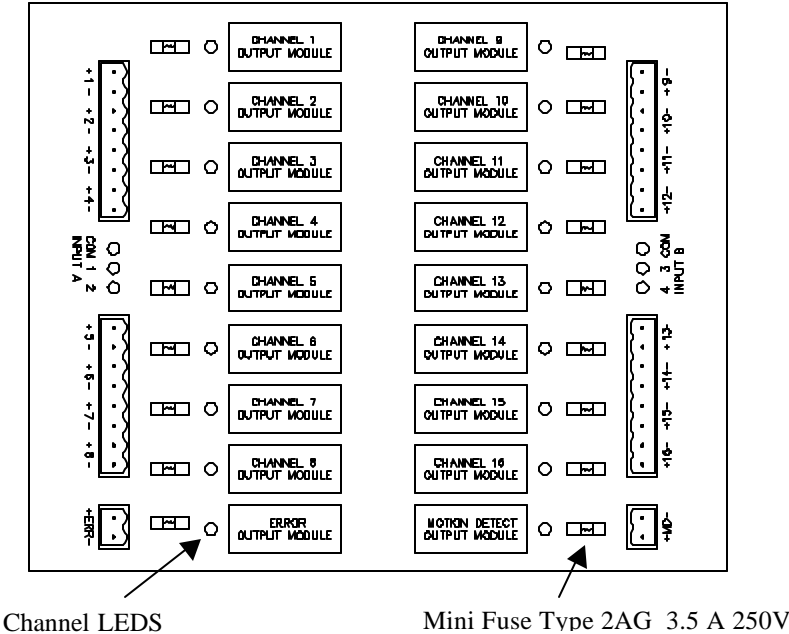

Figure 3.2.6B PLS-801 Solid State Output Module Board

3.3 TRANSDUCER/CONTROL UNIT INTERFACE CABLE

The CONTROL UNIT is interfaced to the TRANSDUCER via a custom made transducer interface cable. This cable is a 3-pair, individually shielded pairs, which contains an eight pin female plug-connector on one end, and a seven pin female MS-type connector on the other end.

The standard transducer interface cable is wired at the factory to provide an **INCREASING** angular position reading for **CLOCKWISE** rotation of the TRANSDUCER shaft (when looking into the END of the shaft). The wiring diagram for this cable is shown in Figure 3.3A. If an **INCREASING** angular position reading for **COUNTER CLOCKWISE** rotation of the TRANSDUCER shaft is desired, refer to Figure 3.3B for this wiring diagram.

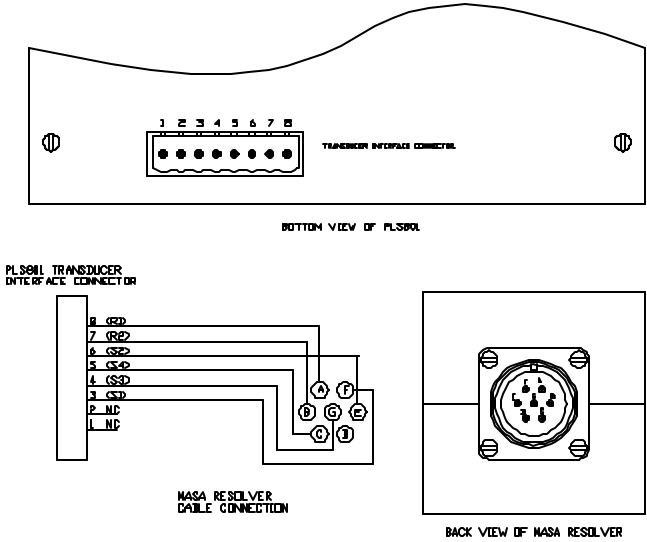

Figure 3.3A
Standard Wiring Diagram (Clockwise transducer shaft rotation)

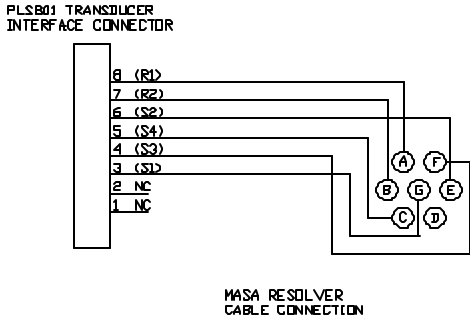

Figure 3.3B
Wiring Diagram (Counter clockwise transducer shaft rotation)

4.0 USING THE PLS-801

It is strongly recommended that this User's Manual be read in its entirety before placing your PLS-801 into operation. Failure to follow the instructions given in this User's Manual may void your PLS-801 warranty.

4.1 INSTALLATION

ALL PLS-801 ELECTRICAL CONNECTORS MUST CONFORM WITH THE NATIONAL ELECTRIC CODE AND ANY LOCAL ELECTRIC CODES IN EFFECT.

IN THE CASE OF ANY DISCREPANCIES BETWEEN THE ELECTRIC CODES AND THESE INSTALLATION INSTRUCTIONS, THE ELECTRIC CODE MUST TAKE PRECEDENT.

4.1.1 MOUNTING THE TRANSDUCER

The TRANSDUCER is designed to be mounted on the target machine, and coupled to the target machine shaft. The TRANSDUCER should be mounted and coupled in a manner such as to minimize shock, vibration, as well as axial and radial shaft loading. The TRANSDUCER may be mounted via the standard front face mount or the optional foot-type mounting adapter.

4.1.2 MOUNTING THE CONTROL UNIT

The PLS-801 Control Unit is designed to be mounted in a NEMA type enclosure, which is suitable for the ambient environment. The enclosure must protect the Control Unit from contamination caused by water, oil, dust, or corrosive gases. The Control Unit should not be subjected to excessive amount of mechanical shock or vibration.

The mounting location should be chosen such as to avoid exposure to significant levels of electromagnetic interference (EMI), which can be induced by devices such as motor starters and control relays. The operating temperature must be maintained between 32°F and 125°F.

4.1.3 CONNECTING THE TRANSDUCER TO THE CONTROL UNIT

The Transducer is connected to the PLS-801 Control Unit via the Transducer/Control Unit Interface Cable. The Cable is a 3-pair, individually shielded pairs, containing an eight pin female plug-connector on one end, and a seven pin female MS-type connector on the other.

The standard Interface Cable is wired at the factory to provide an INCREASING angular position reading for CLOCKWISE rotation of the Transducer shaft (when looking into the END of the shaft). An INCREASING angular position reading during COUNTERCLOCKWISE rotation of the Transducer shaft may be achieved by interchanging two of the wires that are brought into the eight pin female connector. See SECTION 3.3 for complete wiring details.

The Interface Cable may be a maximum length of 2500 feet, and should always be routed in such a manner as to avoid exposure to electromagnetic interference (EMI).

4.1.3 CONNECTING THE TRANSDUCER TO THE CONTROL UNIT - Continued

The seven pin female MS-connector is plugged into the mating seven pin male connector located on the rear of the Transducer.

The eight pin female connector is plugged into the mating eight pin male connector located on the bottom of the PLS-801 Control Unit (See SECTION 3.3).

4.1.4 INSTALLING THE AC POWER CORD

An AC Power Cord is provided with each PLS-801 Control Unit. The female end of the Power Cord should be inserted into the male AC Power Plug located on the side of the Control Unit enclosure.

4.1.5 POWERING ON THE CONTROL UNIT

The Control Unit requires a clean, stable source of AC Power to operate. See SECTION 3.2 for the complete AC Power requirements and specifications of the various Control Unit input power options.

The male end of the AC Power Cord should be inserted into a standard **GROUNDING RECEPTACLE**, which has been wired to provide the AC Power requirements specified in SECTION 3.2.

4.2 PLS-801 PROGRAMMING

PLS-801 offers six standard FUNCTIONS: POSITION, SCALE FACTOR, OFFSET, SETPOINT, TACHOMETER and MOTION. The SCALE FACTOR, OFFSET, SETPOINT and MOTION DETECT functions require the user to enter data via the FRONT PANEL.

Programming is accomplished via four tactile-feel keys: NEXT, INCrement, DECrement, and ENTER. Figure 4.2 depicts the front panel layout of the PLS-801 overlay.

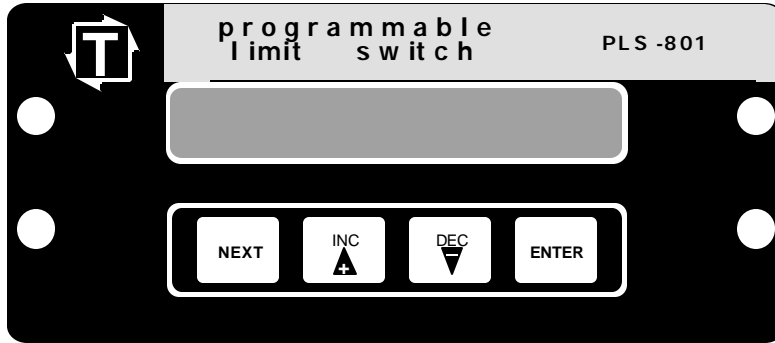

Figure 4.2 PLS-801 Front Panel

Next Key

The **NEXT** key is used to select the desired FUNCTION. Following Power On, the POSITION function is automatically selected. Each time the **NEXT** key is pressed, the functions are selected in the following sequence:

<u>KEY</u>	<u>FUNCTION</u>	<u>DISPLAY</u>
	POSITION	-----_POS_375
NEXT	SCALE FACTOR	SF_1000_POS_375
NEXT	OFFSET	OF__454_POS_375
NEXT	SETPOINT	CH_01__F -T
NEXT	TACHOMETER	-----RPM 050
NEXT	MOTION DETECT	MF020T050RPM_050
NEXT	POSITION	-----_POS_375

INCrement Key

The **INCrement** key is used to set a specific data field to its desired value. Each time the **INCrement** key is pressed and quickly released, the data field value is incremented by one count. However, when the **INCrement** key is pressed and held in, the data field value will be rapidly incremented until the key is released. Each data field value is automatically incremented through its minimum value to its maximum value.

***DEC*rement Key**

The **DEC**rement key may also be used to set a specific data field to its desired value. However, the data field value will be decremented rather than incremented. Each data field value is automatically decremented through its maximum value to its minimum value.

***Enter* Key**

The **ENTER** key is used to enter the currently displayed data field into memory. The **INC**rement and **DEC**rement keys modify only the displayed data field - they do not modify the stored data that is actually used by the **CONTROL UNIT**. In general, an asterisk (*) will appear on the display to indicate that the displayed data value is different from the stored data value, and must be **ENTERED**.

For each of the PLS-801 functions, a **BLINKING** digit on the alphanumeric display specifies the data field at which data may be entered or modified.

4.2.1 POSITION

Upon applying power to the **CONTROL UNIT**, the **POSITION** function is automatically selected. The **POSITION** function is used to display the transducer shaft position (POS), the status of each of the Channel Outputs, and the status of the Motion Detect Output.

Each of the 16 Channel Outputs is assigned a status location on the **POSITION** display. A solid block character in the corresponding location indicates that the Channel Output is **ON**, while a blank character indicates that the Channel Output is **OFF**. The Channel Output status is also displayed by the **TACHOMETER** function. Keep in mind that data entry is not allowed while the PLS is displaying **POSITION**. Figure 4.2.1 depicts the channel output status locations viewable during the **POSITION** display.

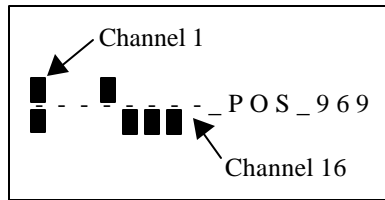

Figure 4.2.1 Channel Output Status Locations

Select: ***NEXT***

Advances the display to the **SCALE FACTOR (SF)** function.

SCALE FACTOR DISPLAY: **SF_1000*_POS_375**

4.2.2 SCALE FACTOR

The **SCALE FACTOR** is the number of increments that the CONTROL UNIT divides one complete TRANSDUCER shaft rotation into. The SCALE function allows the user to enter a 4 digit SCALE FACTOR (SF) value in the range from 0002 to 1000.

The SCALE function also displays the current Transducer shaft POSITION (POS).

NOTE: Upon changing the SCALE FACTOR, the CONTROL UNIT will re-scale the current transducer shaft POSITION, as well as all stored LOBE data. Care should be taken when changing the SCALE FACTOR, as the re-scaling of the LOBE data may produce undesirable rounding.

SCALE FACTOR setup example:

SCALE FACTOR DISPLAY: **SF_1000**_ _POS_375
(Highlighted character indicates blinking character that can be changed)

Select: **INC**
 Increments the SCALE FACTOR value on the display.

NEW DISPLAY: **SF_0002**_ _POS*375
 The asterisk (*) indicates that the new SCALE FACTOR value must be stored into memory via the ENTER key.

Select: **ENTER**
 Stores the new SCALE FACTOR value into memory on the display.

NEW DISPLAY: **SF_0002**_ _POS_375

SCALE FACTOR DISPLAY: **SF_0002**_ _POS_375

Select: **DEC**
 Decrements the SCALE FACTOR value on the display.

NEW DISPLAY: **SF_1000**_ _POS*375
 The asterisk (*) indicates that the new SCALE FACTOR value must be stored into memory via the ENTER key.

Select: **ENTER**
 Stores the new SCALE FACTOR value into memory on the display.

NEW DISPLAY: **SF_1000**_ _POS_375

Select: **NEXT**
 Advances the display to the OFFSET (OF) function.

OFFSET DISPLAY: **OF_ _453**_ _POS_375

4.2.3 OFFSET

The OFFSET is a constant, positive adjustment that the CONTROL UNIT adds to the actual Transducer position to produce the shaft POSITION which is displayed and used by the Control Unit functions. The OFFSET function allows the user to align the Transducer (electrical zero) and machine (mechanical zero) reference points.

The permissible value of the OFFSET parameter is in the range from 0 to the FULL SCALE VALUE.

NOTE: Changing the OFFSET value causes a corresponding change in the displayed shaft POSITION, but does not affect the values of the stored LOBE data.

The OFFSET function also displays the current Transducer shaft POSITION (POS).

OFFSET setup example:

OFFSET DISPLAY: **OF _ 453 _ POS 375**
(Highlighted character indicates blinking character that can be changed)

Select: **INC**
 Increments the OFFSET value on the display.

NEW DISPLAY: **OF _ 454 _ POS*375**
 The asterisk (*) indicates that the new OFFSET value must be stored into memory via the ENTER key.

Select: **ENTER**
 Stores the new OFFSET value into memory on the display.

NEW DISPLAY: **OF _ 454 _ POS 375**

OFFSET DISPLAY: **OF _ 454 _ POS 375**

Select: **DEC**
 Decrements the OFFSET value on the display.

NEW DISPLAY: **OF _ 453 _ POS*375**
 The asterisk (*) indicates that the new OFFSET value must be stored into memory via the ENTER key.

Select: **ENTER**
 Stores the new OFFSET value into memory on the display.

NEW DISPLAY: **OF _ 453 _ POS 375**

Select: **NEXT**
 Advances the display to the SETPOINT function.

SETPPOINT DISPLAY: **CH_01 _ F _ _ -T _ _ _**

4.2.4 SETPOINT

The SETPOINT is used to enter new LOBE data into the CONTROL UNIT memory, as well as to display or modify currently stored LOBE data. SETPOINT allows single or multiple LOBES to be entered on any or all of the 16 Channels. A total of 238 LOBES may be entered.

The TIMING and the DWELL of each LOBE is defined by a FROM position and a TO position. The FROM position defines the TIMING, whereas the difference between the FROM and TO positions defines the DWELL.

The SETPOINT function displays three data fields: CHANNEL NUMBER (CH), FROM position (F), and TO position (T).

<i><u>FUNCTION</u></i>	<i><u>DISPLAY</u></i>	<i><u>FIELD</u></i>	<i><u>RANGE</u></i>
SETPOINT	CH_01_F010-T050	'CH'CHANNEL 'F' FROM Position 'T' TO Position	NUMBER 08, 12 OR 16 000 to Scale Factor-1 000 to Scale Factor-1

PLS-801 allows 'programming through zero', by specifying a FROM field that is larger than the TO field. For example, if the FROM field is specified as '300' and the TO field as '060', the Channel output will turn 'ON' at position '300', remain 'ON' through '000', and be turned 'OFF' at '060'.

Complete details of the various operations that can be performed via the SETPOINT function are given in the following sections:

- 4.2.4.A SELECTING THE CHANNEL NUMBER
- 4.2.4.B DISPLAYING/MODIFYING EXISTING LOBES
- 4.2.4.C ENTERING NEW LOBES
- 4.2.4.D DELETING EXISTING LOBES

4.2.4.A SELECTING THE CHANNEL NUMBER

SETPOINT DISPLAY: **CH_01**_F__-T__
 (Highlighted character indicates blinking character that can be changed)

Select: **INC**
 Increments the CHANNEL NUMBER on the display (e.g. from 01 to 02).

NEW DISPLAY: **CH*02**_F__-T__
 The asterisk (*) indicates that the new CHANNEL NUMBER value must be entered via the ENTER key.

Select: **DEC**
 Decrements the CHANNEL NUMBER on the display (e.g. from 02 to 01).

NEW DISPLAY: **CH*01**_F__-T__
 The asterisk indicates that the new CHANNEL NUMBER must be entered via the ENTER key.

Select: **ENTER**
 Stores the new CHANNEL NUMBER into memory and begins the data entry for LOBE values.

NEW DISPLAY: **CH_01**_F__**-**T__
 If the LOBE data for the F and T fields contains data, then the LOBE parameter has previously been programmed. If the LOBE has not been previously programmed, then only DASHES will be displayed.

4.2.4.B DISPLAYING/MODIFYING EXISTING LOBES

SET EXISTING

LOBE DISPLAY: **CH_01_ _F010-T050**

(Highlighted character indicates blinking character that can be changed. The numbers displayed are for reference purposes only.)

Select: **INC**

Increments the displayed F field to the desired value (e.g. from 010 to 011)

NEW LOBE DISPLAY: **CH_01_ _F011*T050**

The asterisk (*) indicates that the new FROM position must be entered into memory via the ENTER key.

Select: **DEC**

Decrements the displayed F field to the desired value (e.g. from 011 to 010)

NEW LOBE DISPLAY: **CH_01_ _F010*T050**

The asterisk (*) indicates that the new FROM position must be entered into memory via the ENTER key.

Select **ENTER**

Moves the cursor to the T field without entering the displayed data into memory.

NEW LOBE DISPLAY: **CH_01_ _F010*T050**

Lobe data can be entered into the T field.

Select: **INC**

Increments the displayed T field to the desired value (e.g. from 050 to 051)

NEW LOBE DISPLAY: **CH_01_ _F010*T051**

The asterisk (*) indicates that the new FROM position must be entered into memory via the ENTER key.

Select: **DEC**

Decrements the displayed T field to the desired value (e.g. from 051 to 050)

NEW LOBE DISPLAY: **CH_01_ _F010*T050**

The asterisk (*) indicates that the new FROM position must be entered into memory via the ENTER key.

Select: **ENTER**

Enters the displayed data into memory and moves the cursor back to the F field, allowing inspection of the newly stored LOBE data.

NEW LOBE DISPLAY: **CH_01_ _F010-T050**

Asterisk is changed to a dash indicating the LOBE data has been entered into memory successfully.

4.2.4.B DISPLAYING/MODIFYING EXISTING LOBES - Continued

Select: **ENTER**
 Moves the cursor to the T field

NEW LOBE DISPLAY: **CH_01__F010-T050**

Select: **ENTER**
 Moves the cursor to the F field. If the F and T fields contain no data other than dashes, then no additional LOBE data has been entered for Channel 01. Otherwise the next active LOBE is displayed for the selected channel.

NEW LOBE DISPLAY: **CH_01__F__-T__**

Select: **ENTER**
 Moves the cursor to the T field. If the F and T fields contain no data other than dashes, then no additional LOBE data has been entered for Channel 01. Otherwise the next active LOBE is displayed for the selected channel.

NEW LOBE DISPLAY: **CH_01__F__-T__**

Select: **ENTER**
 Automatically selects the next Channel Number and moves the cursor to the F field . The FROM/TO data for the first LOBE of the newly selected channel will be displayed.

NEW LOBE DISPLAY: **CH_02__F038-T126**

You may program up to a maximum of 238 LOBES and up to a maximum of 16 channels if your unit has been equipped with the extra channels. Standard configurations for the PLS801 are 8, 12, and 16 channels. Contact Toledo Transducers for other available configurations.

4.2.4.C ENTERING NEW LOBES

SET NEW LOBE DISPLAY: **CH_01__F__-T__**

(Highlighted character indicates blinking character that can be changed. The numbers displayed are for reference purposes only.)

Select: **INC**

 Increments the displayed F field to the desired value (000 to scale factor - 1)

NEW LOBE DISPLAY: **CH_01__F081*T000**

 The asterisk (*) indicates that the new FROM position must be entered into memory via the ENTER key.

Select: **DEC**

 Decrements the displayed F field to the desired value (scale factor -1 to 000)

NEW LOBE DISPLAY: **CH_01__F080*T000**

 The asterisk (*) indicates that the new FROM position must be entered into memory via the ENTER key.

Select: **ENTER**

 Moves the cursor to the T field without entering the displayed data into memory.

NEW LOBE DISPLAY: **CH_01__F080*T000**

 Lobe data can be entered into the T field.

Select: **INC**

 Increments the displayed T field to the desired value (000 to scale factor -1)

NEW LOBE DISPLAY: **CH_01__F080*T196**

 The asterisk (*) indicates that the new FROM position must be entered into memory via the ENTER key.

Select: **DEC**

 Decrements the displayed T field to the desired value (e.g. from 051 to 050)

NEW LOBE DISPLAY: **CH_01__F080*T195**

 The asterisk (*) indicates that the new FROM position must be entered into memory via the ENTER key.

Select: **ENTER**

 Enters the displayed data into memory and moves the cursor back to the F field, allowing inspection of the newly stored LOBE data.

NEW LOBE DISPLAY: **CH_01__F080-T195**

 Asterisk is changed to a dash indicating the LOBE data has been entered into memory successfully.

4.2.4.C ENTERING NEW LOBES - Continued

Select: **ENTER**

Moves the cursor to the T field

NEW LOBE DISPLAY: **CH_01__F080-T195**

Select: **ENTER**

Moves the cursor to the F field and displays the next active LOBE for the selected channel. You may choose to enter additional LOBES for the FROM field of the selected channel.

NEW LOBE DISPLAY: **CH_01__F__-T__**

Select: **ENTER**

Moves the cursor to the T field and displays the next active LOBE for the selected channel. You may choose to enter additional LOBES for the TO field of the selected channel.

NEW LOBE DISPLAY: **CH_01__F__-T__**

Select: **ENTER**

Automatically selects the next Channel Number and moves the cursor to the F field. The FROM/TO data for the first LOBE of the newly selected channel will be displayed.

NEW LOBE DISPLAY: **CH_02__F__-T__**

You may program up to a maximum of 238 LOBES and up to a maximum of 16 channels if your unit has been equipped with the extra channels. Standard configurations for the PLS801 are 8, 12, and 16 channels. Contact Toledo Transducers for other available configurations.

4.2.5 TACHOMETER

The TACHOMETER function is used to display the Transducer shaft speed in RPM, the status of the Motion Detect Output, and the status of the Channel Outputs.

The status of the Motion Detect Output is displayed in the TACHOMETER and POSITION functions. An "M" character in the Motion Detect status location indicates that shaft RPM is within the Motion Detect window (ON), while a blank character indicates that the shaft RPM value falls outside of the Motion Detect window (OFF).

TACHOMETER DISPLAY: ----- **MRPM_010**
 (Motion Detect Output Status = ON)

TACHOMETER DISPLAY: ----- **_RPM_010**
 (Motion Detect Output Status = OFF)

Select: **NEXT**
 Advances the display to the Motion Detect (MF) function and places the cursor into the MF data field.

MOTION DETECT DISPLAY: **MF020T040RPM_010**

4.2.6 MOTION DETECT

MOTION DETECT allows the user to set a window for shaft speed, and receive an indication that the shaft speed falls within the window via the POSITION function, the TACHOMETER function, and the Motion Detect output. The window is defined by MOTION FROM ('MF') and MOTION TO ('MT') RPM values. SHAFT RPM values EQUAL to the 'MF' or 'MT' values are considered to be WITHIN the window.

NOTE: If the 'MF' field is less than the 'MT' field, the MD status will be 'ON' when the shaft speed is within the MD window, and 'OFF' when it is outside of the window. If the 'MF' field is greater than the 'MT' field, the MD status will be 'OFF' when the shaft speed is within the MD window, and 'ON' when it is outside of the window.

MOTION DETECT DISPLAY: **MF020T040RPM_010**
 (Highlighted character indicates blinking character that can be changed. The numbers displayed are for reference purposes only.)

Select: **INC**
 Increments the value in the F field of the MOTION DETECT function.

NEW DISPLAY: **MF021T040RPM*010**
 The asterisk (*) indicates that the new MF value must be stored into memory via the ENTER key.

Select: **DEC**
 Decrements the value in the F field of the MOTION DETECT function.

NEW DISPLAY: **MF020T040RPM*010**
 The asterisk (*) indicates that the new MF value must be stored into memory via the ENTER key.

Select: **ENTER**
 Moves the cursor to the T field without entering the displayed data into memory.

4.2.6 MOTION DETECT - Continued

NEW DISPLAY: **MF020T040RPM*010**

Select: *INC*
 Increments the value in the T field of the MOTION DETECT function.

NEW DISPLAY: **MF021T040RPM*010**

 The asterisk (*) indicates that the new MT value must be stored into memory via the ENTER key.

Select: *DEC*
 Decrements the value in the T field of the MOTION DETECT function.

NEW DISPLAY: **MF020T040RPM*010**

 The asterisk (*) indicates that the new MT value must be stored into memory via the ENTER key.

Select: *ENTER*
 Enters the displayed data into memory and moves the cursor back to the F field, allowing inspection of the newly stored MOTION DETECT data.

NEW DISPLAY: **MF020T040RPM_010**

Select: *NEXT*
 Advances the display to the POSITION (POS) function. This is the data display used to indicate resolver position and output relay status.

NEW DISPLAY: **- - - - - _ P O S _ 9 6 9**

4.3 ERROR CONDITIONS

The ERR Output on the PLS-801 Output Board (see section 3.2.6 for details) can be used to provide a hardware indication that one of the following Control Unit error conditions has occurred:

- ❑ TRANSDUCER SIGNAL ERROR
- ❑ CONTROL UNIT MICROPROCESSOR FAULT
- ❑ LOSS OF AC POWER

The ERR Output is held ON by the Control Unit hardware. Should any of the Control Unit errors occur, the ERR Output will be turned OFF to indicate an error condition exist.

4.3.1 TRANSDUCER SIGNAL ERROR

If any of the Interface Cable wires become disconnected or broken, the following error indications will be given by the Control unit:

- 1) The Channel Outputs, Motion Detect Output and ERR Output will be set low
- 2) The Channel Output Relays, Motion Detect Relay and Fault Check Relay will be opened.
- 3) An error message will be placed on the front panel display (if attached), when any of the following functions are selected: (No error message is given if the SETPOINT function is currently selected.)

FUNCTION	DISPLAY
POSITION	----- _POS_ERR
SCALE FACTOR	SF_1000_POS_ERR
OFFSET	OF_434_POS_ERR
TACHOMETER	----- _RPM_ERR
MOTION DETECT	MF020T040RPM__ERR

- 4) Normal programming will be allowed during this error condition

4.3.2 CONTROL UNIT MICROPROCESSOR FAULT

In the event of a microprocessor fault, the alphanumeric display, Channel Output and Channel Output Relays are frozen in the state that existed at the time of the fault. Because a microprocessor fault is detected by the Control Unit hardware, the Fault Check Relay can be used to give an indication that a fault has occurred. The Fault Check Relay will be held closed during normal operation, and will be opened by a microprocessor fault.

4.3.3 LOSS OF AC POWER

In the event of a loss of AC power, the Control Unit will cease all operations, resulting in the following conditions:

- 1) The front panel display will become blank
- 2) The Channel Outputs, Motion Detect Output and Fault Check Outputs will be set low
- 3) The Channel Output Relays, Motion Detect Relay and Fault Check Relay will be opened.

NOTE: Because the program data is stored in non-volatile EEPROM memory, it will not be lost as a result of a loss of AC power.