

PEM-300 Manual

TABLE of CONTENTS

1.	Introduction.....	Page 1
2.	PEM-300 Part Ejection Monitor Description	Page 2
3.	PEM-300 Part Ejection Monitor Typical Installation.....	Page 3
4.	PEM-300 Part Ejection Monitor Operation	Page 5
5.	PEM-300 Compatible Modules	Page 6
6.	PEM-300 Part Ejection Timing	Page 9
7.	PEM-300 Mechanical Dimensions	Page 10
8.	PEM-300 Wiring Diagram.....	Page 11
9.	Limited Warranty.....	Page 12

TABLE of FIGURES

Figure 3.1 PEM-300 SystemPage 3

Figure 3.2 PEM-300 Press InstallationPage 4

Figure 4.1 PEM-300 Front PanelPage 5

Figure 5.1 B-502 Single Station Part Ejection ModulePage 6

Figure 5.2 B-504 CAM Input Timing ModulePage 7

Figure 5.3 LS-3 Light Screen Set.....Page 8

Figure 6.1 Typical Part Ejection Timing.....Page 9

Figure 7.1 PEM-300 Mechanical DimensionsPage 10

Figure 8.1 PEM-300 Control Board Wiring DiagramPage 11

1**Introduction**

The purpose of this User's Manual is to describe the operation, and installation of the MASA (Toledo Transducer's) PEM-300 Part Ejection Monitor (herein referred to as the PEM-300). It is strongly recommended that this User's Manual be read entirely before placing the PEM-300 into operation. Failure to follow the instructions given in this User's Manual may void your PEM-300 warranty.

Questions regarding any aspect of the PEM-300 should be referred to Toledo Transducers, Inc.:

**Toledo Transducers, Inc.
6834 Spring Valley Drive
Holland, Ohio 43528**

**Phone: (419) 867-4170
Fax: (419) 867-4180**

2

PEM – 300 Part Ejection Monitor Description

The PEM-300 Part Ejection Monitoring system is used to detect the occurrence of improper part ejections that could lead to the catastrophic destruction of the press. Part ejection detection is accomplished through the use of multiple electronic modules used within the PEM-300. When a fault condition is detected, the PEM-300 will immediately open its E-Stop relay. If the relay is connected to the press's E-Stop circuitry, the press will shut down.

The PEM-300 includes a B-504 cam check module that continuously monitors the state of the cam timing. The B-504 module also produces the main timing for the part ejection module that is incorporated in to the system.

SPECIFICATIONS:

Power Requirements:	115 VAC, 60Hz.
Voltage Tolerance:	± 10 VAC
PEM 300 Control Unit:	10½”L x 7½”H x 6¼”W
B-504 Module:	CAM Check module standard with each PEM control unit (monitors CAM timing)
Power Supply:	18 VDC, 180 mA (MAX.) for sensors
Outputs:	E-STOP (dry contact, 10A at 120VAC, 240VAC, 30VDC)
Operational Speed:	Up to 1200 SPM

3 PEM – 300 Part Ejection Monitor Typical Installation

CAUTION:

The location of the PEM-300 Part Ejection Monitor control unit should be as close as possible to the press controls, allowing easy access to the press operator. The unit should be located away from any oil or lubricant sprays. The location chosen must be convenient for operation and for the safety of the PEM control unit.

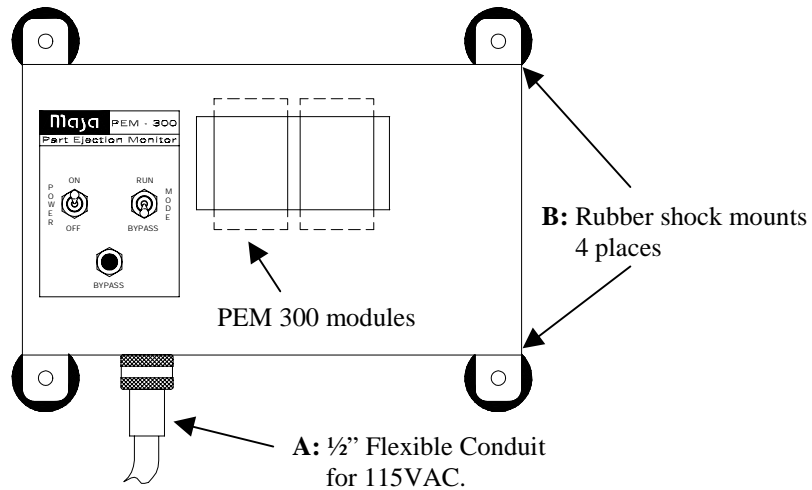
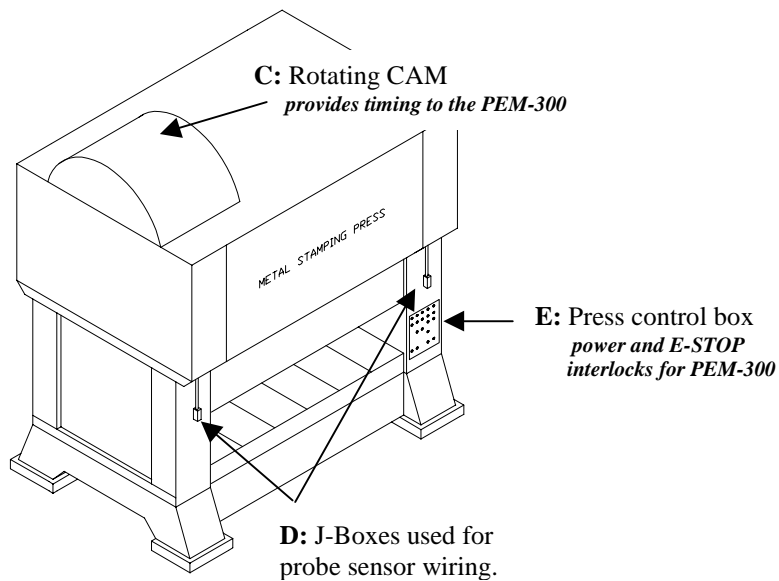

Figure 3.1 PEM-300 System

Refer to Figure 3.1 for the following suggestions.

- A:** Use 1/2" flexible conduit at this location for all 115VAC power. *115VAC is required to power the PEM-300 control unit. It may also be required for the E-STOP circuitry in some applications.*
- B:** Rubber shock mounts should always be used as a precaution to applications that are prone to excessive vibration. Dampening excessive vibration will prolong the operating life of the PEM-300 control unit.

3

PEM – 300 Part Ejection Monitor Typical Installation - Continued**Figure 3.2 PEM-300 Press Installation**

Refer to Figure 3.2 for the following suggestions.

- C:** The PEM-300 control unit must be timed to the crankshaft of the punch press.
*The timing relationship between the press crank and the PEM-300 must be a 1:1 ratio.
 If the timing ratio is not 1:1, the PEM-300 will not monitor the press die at the correct crank position.
 This could ultimately lead to catastrophic destruction of the press.*
- D:** Any standard junction box can be used for installation of the sensors used in conjunction with the PEM-300. The use of junction boxes is left to the discretion of the system installer.
- E:** The existing press control box will provide A.C. power and an E-STOP interlock to the PEM-300 control unit. For good electrical noise immunity, the A.C. power must be routed through separate conduit than that of the sensor wires.

4

PEM – 300 Part Ejection Monitor Operation

The PEM-300 Part Ejection Monitor that you purchased has been pre-installed with a standard CAM input module and a part ejection module. The functionality of these modules will be described within section Five of this manual. This section describes the front panel operation of the PEM-300. Refer to Figure 4.1 for the front panel operation description of the PEM-300 control unit.

4.1 PEM-300 Front Panel Operation

Figure 4.1
PEM-300 Front Panel

A: Power Switch

Used to apply and remove power from the PEM-300 control unit.

B: Mode Switch

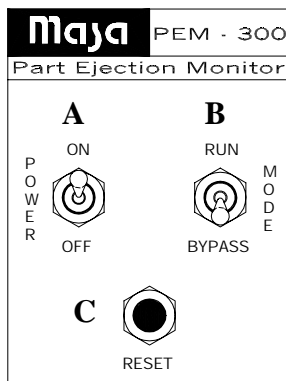
Place the Mode Switch in the “BYPASS” position when setting up dies or loading stock material. Placing the Mode Switch to the “BYPASS” position will allow the press to operate independently of the PEM-300 control unit. Once all the sensors have been properly set and the material has been properly loaded in to the die area, place the Mode Switch in to the “RUN” position. The PEM-300 control unit is now ready to monitor all stations. The press can now be operated in continuous mode.

C: Reset Switch

Once the PEM-300 is placed in to “RUN” mode, the user must press the “RESET” switch within ten to twelve seconds in order to operate the press in continuous mode. If this does not take place, the PEM-300 will issue a FAULT and the “RESET” switch will have to be pressed again.

If a FAULT condition is detected in any monitored station, the PEM-300 will immediately shut the press down by activating its E-STOP output relay. Once the problem has been determined and corrected, pressing the “RESET” switch will deactivate the E-STOP relay. The press can resume operation in continuous mode.

5

PEM – 300 Compatible Modules**5.1 B-502 Single Station Part Ejection Module**

Figure 5.1
B-502 Module

The B-502 single station PART EJECTION module can be used to detect proper ejection of material that takes place during the press operation. The following describes the functions of the B-502 module.

Sensor Blocked (Red LED):

When active, a fault condition has occurred that indicates the part ejection sensor (light screen beam) is either blocked by the part, blocked by an object, is dirty, or simply out of alignment at the time the rotary cam switch is closing. The press will stop if this condition is recognized.

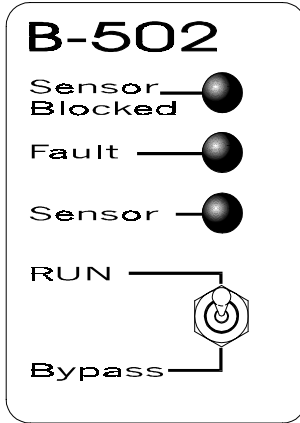
Fault (Red LED):

When the Fault LED is active, an improper part ejection sequence has been recognized. It is an indication that the part has not left the die area at the time the rotary cam switch is closing. The press will stop during this condition.

Sensor (Green LED):

The Sensor LED is active anytime a part passes through the beam. This LED will also remain illuminated during light screen setup up. It will turn off when correct sensor alignment is achieved.

RUN/Bypass (Toggle Switch):

The RUN/Bypass switch is used to disable the B-502 module. When the switch is in the Bypass position, the B-502 module will not stop the press even though an improper part ejection condition may exist. It is used to disable the functionality of the module. Placing the switch in the RUN position will allow the B-502 to monitor the proper die operation and stop the press during fault conditions.

See the timing diagram in section 6 for typical timing sequence for the B-502 single station part ejection module.

5.2 B-504 CAM Input Timing Module

Figure 5.2
B-504 Module

The B-504 CAM input module is used to provide the system timing for the PEM-300 Part Ejection Monitor. By monitoring the opening and closing of the rotary cam switch, the appropriate timing for the other modules in the system is generated. This module is standard with the PEM-300 system and is preinstalled at the factory. This module must reside in the leftmost socket of the PEM-300 control board.

The following describes the functions of the B-504 module.

READY (Yellow LED):

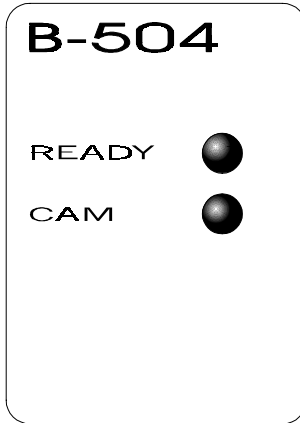
The READY LED indicates that the B-504 module has either detected that the reset switch has been pressed or that the closure of the rotary cam switch contacts has occurred. When active, it indicates that the module is ready to monitor press activity. If the PEM-300 front panel reset switch has been pressed, the user has approximately twelve seconds to start the press. If the user has not started the press during this allotted time, the B-504 module will reset and the READY LED will turn off. The PEM-300 system will not operate until the front panel reset switch is once again pushed.

CAM (Yellow LED):

The CAM LED is active anytime the rotary cam switch contacts are closed.

PEM – 300 Compatible Modules - Continued**5.3 LS-3 Light Screen Set**

Figure 5.3
LS 3 - Light Screen

The LS-3 LIGHT SCREEN SET consist of an infrared light emitting and an infrared light detector pair. These units are used in conjunction with the B-502 part ejection module. For correct operation of the PEM-300 part ejection system, the part must pass completely through the beam each cycle. If this does not occur, the PEM-300 will stop the press.

The LS-3 light screen set should be placed as close as possible to the part ejection area for quick part ejection detection. Placing the LS-3 light screen in close proximity to the part ejection area minimizes travel time of the part being monitored. The emitter can be placed up to 48 inches from the detector.

The LS-3 light screen is connected to the PEM-300 part ejection system via a 15 ft. cable. This cable is pre-wired at the factory.

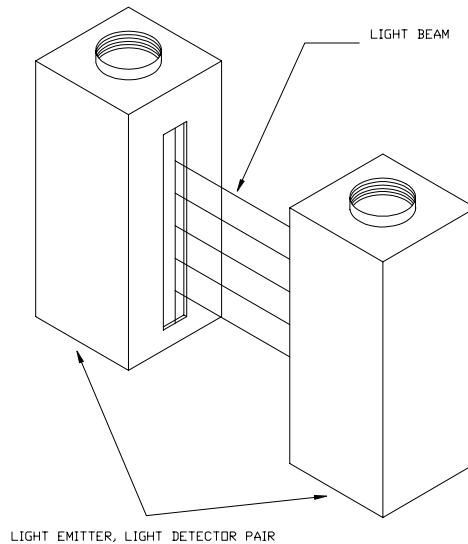
6

PEM 300 – Part Ejection Timing

After the installation of the PEM-300 has been completed, (sensor placement, cable routing, etc.), the CAM timing must be setup in order for the part ejection system to correctly work. To begin this task, start jogging the press.

Take notice of the point where the material has been completely passed through the light beam of the LS-3. light screen. The LS-3 light screen should be placed as close as possible to the part ejection area so that part travel is minimized. Once these points have been determined, jog the press an additional 20 to 30 degrees, then set the rotary CAM switch to close its contacts at this position.

The rotary CAM switch closing dwell time should *always* be between 150 and 180 degrees for proper part ejection operation of the PEM-300 system. Refer to Figure 6.1 for typical part ejection timing.

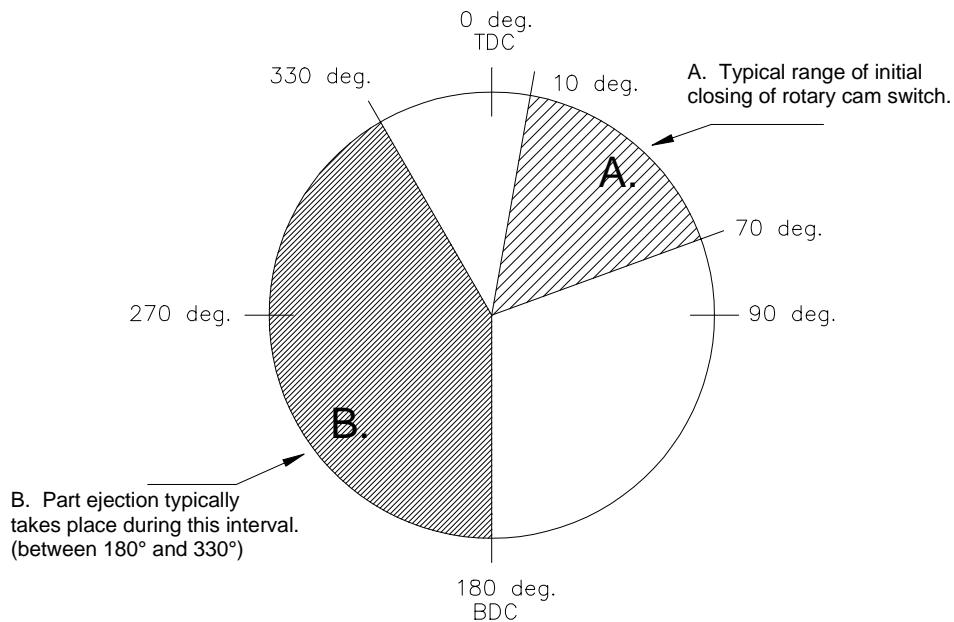

Figure 6.1 Typical Part Ejection Timing

7

PEM – 300 Mechanical Dimensions

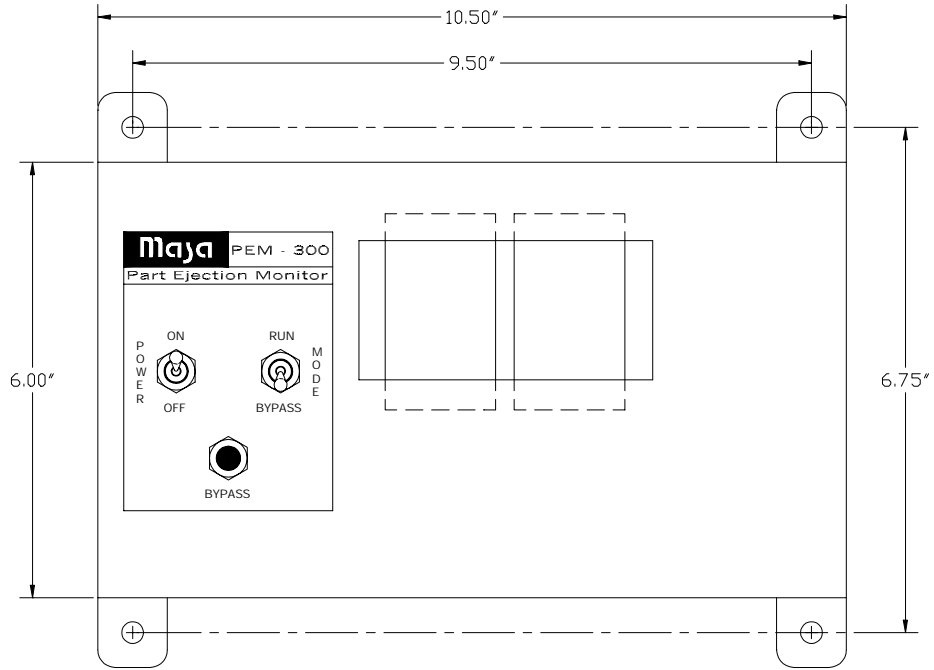

Figure 7.1 PEM-300 Mechanical Dimensions

8

PEM – 300 Wiring Diagram

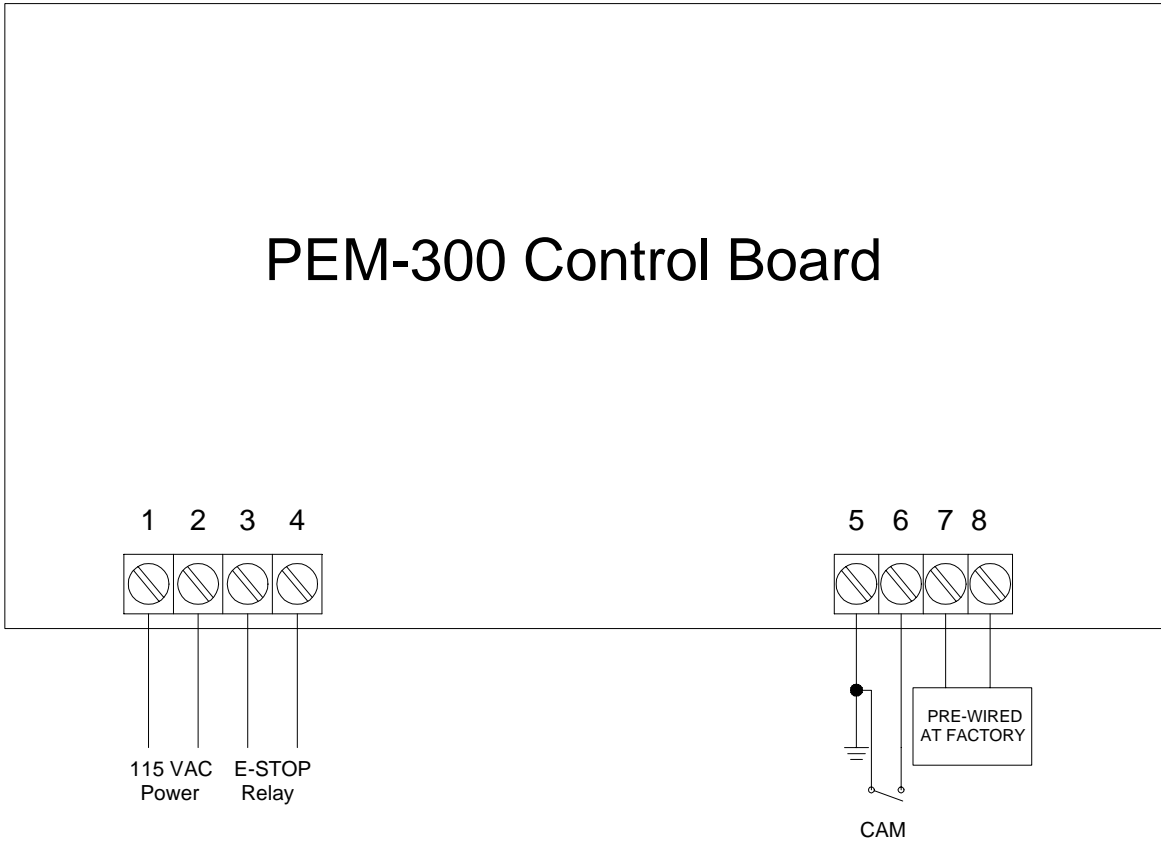

Figure 8.1 PEM-300 Control Board Wiring Diagram

Limited Warranty

This unit is warranted by the manufacturer, Toledo Transducers, Inc., to be free of defects in workmanship and materials for one year from date of manufacturer's shipment. This warranty is limited to repairing or replacing products which manufacturer's investigation shows were defective at the time of shipment by the manufacturer.

All products subject to this warranty must be returned for examination, repair, or replacement to:

***F.O.B. Toledo Transducers, Inc.
6834 Spring Valley Drive
Holland, Ohio 43528***

The express warranty set forth herein is in lieu of all other warranties, expressed or implied, including without limitation any warranties of merchant-ability or fitness for a particular purpose. All such warranties are hereby disclaimed and excluded by the manufacturer.

Repair or replacement of defective products as provided above is the sole and exclusive remedy provided thereunder. The manufacturer shall not be liable for any further loss, damages, or expenses, including incidental or consequential damages, directly or indirectly arising from the sale or use of this product.

Any unauthorized repair voids this warranty.

There are no warranties that extend beyond those expressly set forth herein.