



**Toledo Transducers**

**DMS - 302**  
**Die Monitor System**  
**User's Manual**

**Rev. 2**

## **Limited Warranty**

This unit is warranted by the manufacturer, Toledo Transducers, Inc., to be free of defects in workmanship and materials for one year from date of manufacturer's shipment. This warranty is limited to repairing or replacing products which manufacturer's investigation shows were defective at the time of shipment by the manufacturer.

All products subject to this warranty must be returned for examination, repair, or replacement to:

***F.O.B. Toledo Transducers, Inc.  
6834 Spring Valley Drive  
Holland, Ohio 43528***

***The express warranty set forth herein is in lieu of all other warranties, expressed or implied, including without limitation any warranties of merchantability or fitness for a particular purpose. All such warranties are hereby disclaimed and excluded by the manufacturer.***

Repair or replacement of defective products as provided above is the sole and exclusive remedy provided thereunder. The manufacturer shall not be liable for any further loss, damages, or expenses, including incidental or consequential damages, directly or indirectly arising from the sale or use of this product.

Any unauthorized repair voids this warranty.

There are no warranties that extend beyond those expressly set forth herein.

**TABLE of CONTENTS**

- 1. Introduction.....Page 1
- 2. DMS-302 Die Monitor System Description .....Page 2
- 3. DMS-302 Die Monitor System Typical Installation.....Page 3
- 4. DMS-302 Die Monitor System Operation .....Page 5
- 5. DMS-302 Compatible Modules .....Page 6
- 6. DMS-302 Rotary CAM Timing .....Page 11
- 7. DMS-302 Mechanical Dimensions.....Page 13
- 8. DMS-302 Wiring Diagram .....Page 14

**TABLE of FIGURES**

|             |   |         |
|-------------|---|---------|
| Figure 3.1  | DMS-302 System .....                              | Page 3  |
| Figure 3.2  | DMS-302 Press Installation.....                   | Page 4  |
| Figure 4.1  | DMS-302 Front Panel.....                          | Page 5  |
| Figure 5.1a | B-501 Single Station Misfeed Module .....         | Page 6  |
| Figure 5.1b | B-506 Dual Station Misfeed Module.....            | Page 6  |
| Figure 5.2  | B-502 Single Station Part Ejection Module .....   | Page 7  |
| Figure 5.3a | B-503 Single Station Material Buckle Module ..... | Page 8  |
| Figure 5.3b | B-505 Dual Station Material Buckle Module.....    | Page 8  |
| Figure 5.4  | B-504 CAM Input Timing Module .....               | Page 9  |
| Figure 5.5  | B-507 Misfeed and Material Buckle Module .....    | Page 10 |
| Figure 6.1  | Rotary CAM switch timing for the DMS-302.....     | Page 12 |
| Figure 6.2  | Operating Sequence for Rotary Cam Switch.....     | Page 12 |
| Figure 7.1  | DMS-302 Mechanical Dimensions .....               | Page 13 |
| Figure 8.1  | DMS-302 Basic Wiring Diagram .....                | Page 14 |

**1****Introduction**

The purpose of this User's Manual is to describe the operation, and installation of the MASA (Toledo Transducer's) DMS-302 Die Monitor System (herein referred to as the DMS-302). It is strongly recommended that this User's Manual be read entirely before placing the DMS-302 into operation. Failure to follow the instructions given in this User's Manual may void your DMS-302 warranty.

Questions regarding any aspect of the DMS-302 should be referred to Toledo Transducers, Inc.:

**Toledo Transducers, Inc.  
6834 Spring Valley Drive  
Holland, Ohio 43528**

**Phone: (419) 867-4170  
Fax: (419) 867-4180**

## 2

**DMS – 302 Die Monitor System Description**

The DMS-302 Die Monitoring system is used to detect various conditions within the metal stamping process that could lead to catastrophic destruction of the press. Through the use of multiple electronic modules, the DMS-302 can protect against short stock feeds, long stock feeds, improper part ejection, and stock buckling. When a fault condition is detected, the DMS-302 will immediately open its E-Stop relay. If the relay is connected to the press's E-Stop circuitry, the press will shut down.

The DMS-302 includes a B-504 cam check module that continuously monitors the state of the cam timing. The B-504 module also produces the main timing for the other modules that may be incorporated in to the system. The DMS-302 can be expanded to provide up to four monitoring stations by using B-500 series single and double station modules. These modules can monitor any combination of cyclic or non-cyclic inputs.

**SPECIFICATIONS:**

|                       |   |
|-----------------------|---|
| Power Requirements:   | 115 VAC, 60Hz.  |
| Voltage Tolerance:    | ± 10 VAC  |
| DMS 302 Control Unit: | 10½”L x 7½”H x 6¼”W   |
| B-504 Module:         | CAM Check module standard with each<br>DMS control unit (monitors CAM timing) |
| Power Supply:         | 18 VDC, 180 mA (MAX.) for sensors   |
| Sensor Inputs:        | Sensors with NPN sinking output, or with grounded sensor probes.              |
| Outputs:              | E-STOP (dry contact, 10A at 120VAC, 240VAC, 30VDC)                            |
| Operational Speed:    | Up to 1200 SPM  |

## 3

**DMS – 302 Die Monitor Typical Installation****CAUTION:**

The location of the DMS-302 Die Monitoring control unit should be as close as possible to the press controls, allowing easy access to the press operator. The unit should be located away from any oil or lubricant sprays. The location chosen must be convenient for operation and for the safety of the DMS control unit.

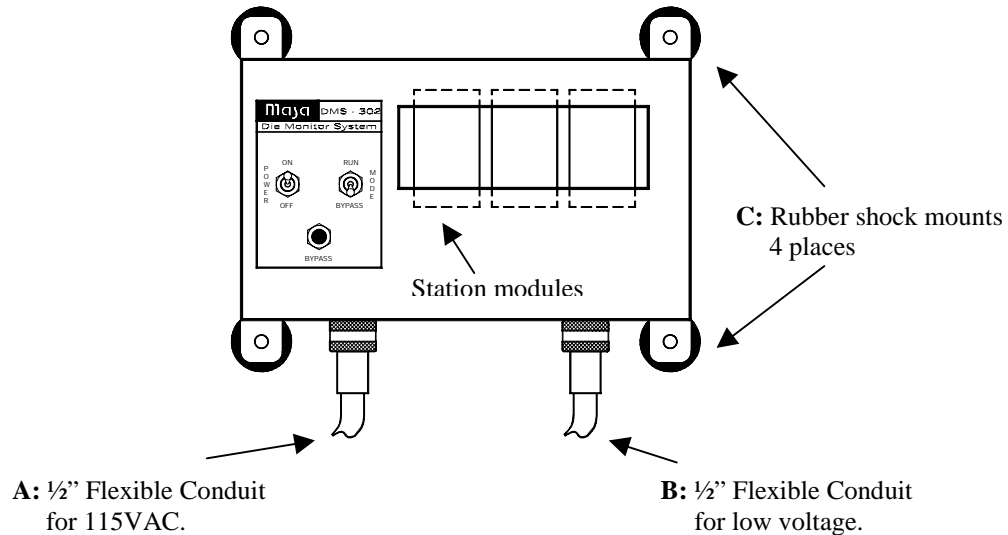
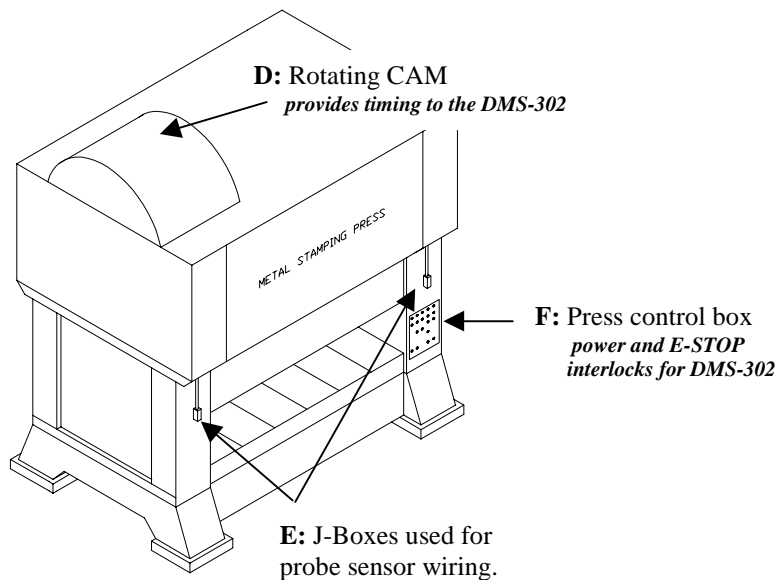

**Figure 3.1 DMS-302 System**

Refer to Figure 3.1 for the following suggestions.

- A:** Use ½" flexible conduit at this location for all 115VAC power. *115VAC is required to power the DMS-302 control unit. It may also be required for the E-STOP circuitry in some applications.*
- B:** Use ½" flexible conduit at this location for all low voltage inputs that are used for sensor and timing cam inputs. *It is highly recommended that all low voltage wires be routed through separate conduit in order to prevent electrical noise interference to the DMS-302 control unit.*
- C:** Rubber shock mounts should always be used as a precaution to applications that are prone to excessive vibration. Dampening excessive vibration will prolong the operating life of the DMS-302 control unit.

## 3

**DMS – 302 Die Monitor Typical Installation - Continued****Figure 3.2 DMS-302 Press Installation**

Refer to Figure 3.2 for the following suggestions.

- D:** The DMS-302 control unit must be timed to the crankshaft of the punch press.  
*The timing relationship between the press crank and the DMS-302 must be a 1:1 ratio. If the timing ratio is not 1:1, the DMS-302 will not monitor the press die at the correct crank position. This could ultimately lead to catastrophic destruction of the press.*
- E:** Any standard junction box can be used for installation of the sensors used in conjunction with the DMS-302. The use of junction boxes is left to the discretion of the system installer.
- F:** The existing press control box will provide A.C. power and an E-STOP interlock to the DMS-302 control unit. For good electrical noise immunity, the A.C. power must be routed through separate conduit than that of the sensor wires.

## 4

**DMS – 302 Die Monitor System Operation**

The DMS-302 Die Monitor System that you purchased has been pre-installed with station modules that were specified during order placement. The functionality of these modules will be described within section Five of this manual. This section describes the front panel operation of the DMS-302. Refer to Figure 4.1 for the front panel operation description of the DMS-302 control unit.

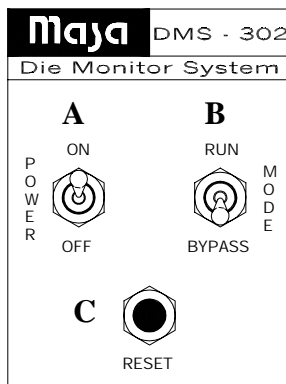
**4.1 DMS-302 Front Panel Operation**

**Figure 4.1**  
**DMS-302 Front Panel**

**A: Power Switch**

Used to apply and remove power from the DMS-302 control unit.

**B: Mode Switch**

Place the Mode Switch in the “BYPASS” position when setting up dies or loading stock material. Placing the Mode Switch to the “BYPASS” position will allow the press to operate independently of the DMS-302 control unit. Once all the sensors have been properly set and the material has been properly loaded in to the die area, place the Mode Switch in to the “RUN” position. The DMS-302 control unit is now ready to monitor all stations. The press can now be operated in continuous mode.

**C: Reset Switch**

Once the DMS-302 is placed in to “RUN” mode, the user must press the “RESET” switch within ten to twelve seconds in order to operate the press in continuous mode. If this does not take place, the DMS-302 will issue a FAULT and the “RESET” switch will have to be pressed again.

If a FAULT condition is detected in any monitored station, the DMS-302 will immediately shut the press down by activating its E-STOP output relay. Once the problem has been determined and corrected, pressing the “RESET” switch will deactivate the E-STOP relay. The press can resume operation in continuous mode.

## 5

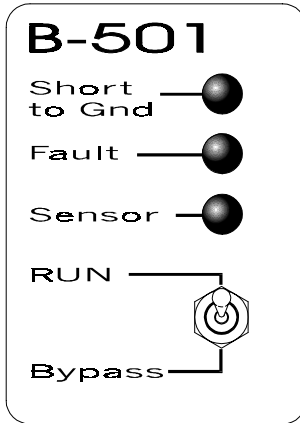
**DMS – 302 Compatible Modules****5.1 B-501/B-506 Misfeed (Shortfeed) Detection Module**

**Figure 5.1a**  
**B-501 Single Station**  
**Module**

The B-501/B-506 MISFEED DETECTION module can be used to detect any type of material misfeeds that take place during the press operation. The B-501 is the single station module while the B-506 is the dual station module. The following describes the functions of the B-501/B506 module.

**Short to Gnd (Red LED):**

When active, a fault condition has occurred that indicates the misfeed sensor has made contact with the end of the material strip at the time the rotary cam switch re-opened. The press will stop if this condition is recognized. Short to Gnd is a “FAIL SAFE” circuit. The misfeed sensor must make contact with the material at the beginning of every press stroke.

**Fault (Red LED):**

When the Fault LED is active, a misfeed condition has occurred. It is an indication that material stock is jammed in the die area and has failed to make contact with the misfeed sensor prior to initial closing of the rotary cam switch contacts. The press will stop during this condition.

**Sensor (Green LED):**

The Sensor LED is active anytime contact is made between the misfeed sensor and the material. It remains on until the misfeed sensor is no longer in contact with the material.

**RUN/Bypass (Toggle Switch):**

The RUN/Bypass switch is used to disable the B-501/B-506 module. When the switch is in the Bypass position, the B-501/B-506 module will not stop the press even though a misfeed condition may exist. It is used to disable the functionality of the module. Placing the switch in the RUN position will allow the B-501/B506 module to monitor the proper die operation and stop the press during fault conditions.

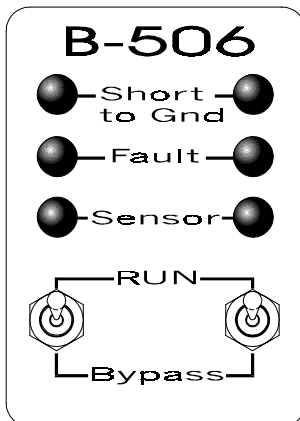

**Figure 5.1b**  
**B-506 Dual Station**  
**Module**

See the timing diagram in section 6 for typical timing sequence for the B-501/B-506 Misfeed Detection Module.

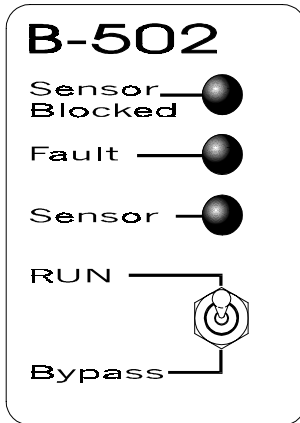
**DMS – 302 Compatible Modules - Continued****5.2 B-502 Single Station Part Ejection Module**

**Figure 5.2**  
**B-502 Module**

The B-502 single station PART EJECTION module can be used to detect proper ejection of material that takes place during the press operation. The following describes the functions of the B-502 module.

**Sensor Blocked (Red LED):**

When active, a fault condition has occurred that indicates the part ejection sensor (light screen beam) is either blocked by the part, blocked by an object, is dirty, or simply out of alignment at the time the rotary cam switch is closing. The press will stop if this condition is recognized.

**Fault (Red LED):**

When the Fault LED is active, an improper part ejection sequence has been recognized. It is an indication that the part has not left the die area at the time the rotary cam switch is closing. The press will stop during this condition.

**Sensor (Green LED):**

The Sensor LED is active anytime a part passes through the beam. This LED will also remain illuminated during light screen setup up. It will turn off when correct sensor alignment is achieved.

**RUN/Bypass (Toggle Switch):**

The RUN/Bypass switch is used to disable the B-502 module. When the switch is in the Bypass position, the B-502 module will not stop the press even though an improper part ejection condition may exist. It is used to disable the functionality of the module. Placing the switch in the RUN position will allow the B-502 to monitor the proper die operation and stop the press during fault conditions.

See the timing diagram in section 6 for typical timing sequence for the B-502 single station part ejection module.

5

**DMS – 302 Compatible Modules - Continued**

**5.3 B-503/B-505 Material Buckle Module**

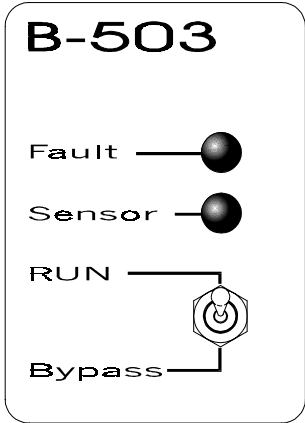

**Figure 5.3a  
B-503 Single Station  
Module**

The B-503/B-505 MATERIAL BUCKLE module can be used to detect proper material feed in to the die area. The B-503 is the single station module while the B-505 is the dual station module. Conditions such as material buckle, end of stock, long feed, hot pilot, etc... can be monitored. This module functions independently of the rotary cam switch and will produce a fault response immediately upon recognizing the error condition without involving cam timing. The following describes the functions of the B-503/B-505 module.

**Fault (Red LED):**

When active, a fault condition has occurred in the die area indicating that material has made contact with the sensor. The press will stop during this condition.

**Sensor (Green LED):**

The Sensor LED is active anytime material makes contact with the sensor.

**RUN/Bypass (Toggle Switch):**

The RUN/Bypass switch is used to disable the B-503/B-505 module. When the switch is in the Bypass position, the B-503/B-505 module will not stop the press even though a fault condition may exist. It is used to disable the functionality of the module. Placing the switch in the RUN position will allow the B-503/B-505 to monitor the proper die operation and stop the press during fault conditions.

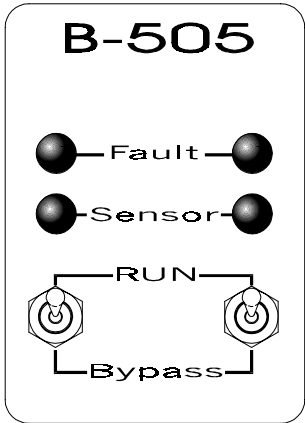

**Figure 5.3b  
B-505 Dual Station  
Module**

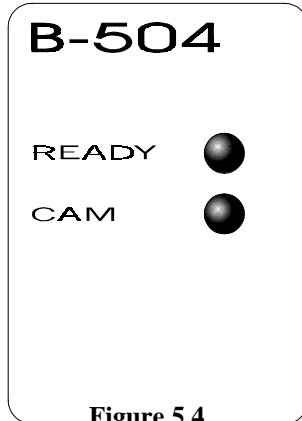
**5.4 B-504 CAM Input Timing Module**

**Figure 5.4**  
**B-504 Module**

The B-504 CAM input module is used to provide the system timing for the DMS-302 Die Protection System. By monitoring the opening and closing of the rotary cam switch, the appropriate timing for the other modules in the system is generated. This module is standard with the DMS-302 system and is preinstalled at the factory. This module must reside in the leftmost socket of the DMS-302 control board.

The following describes the functions of the B-504 module.

**READY (Yellow LED):**

The READY LED indicates that the B-504 module has either detected that the reset switch has been pressed or that the closure of the rotary cam switch contacts has occurred. When active, it indicates that the module is ready to monitor press activity. If the DMS-302 front panel reset switch has been pressed, the user has approximately twelve seconds to start the press. If the user has not started the press during this allotted time, the B-504 module will reset and the READY LED will turn off. The DMS-302 system will not operate until the front panel reset switch is once again pushed.

**CAM (Yellow LED):**

The CAM LED is active anytime the rotary cam switch contacts are closed.

**DMS – 302 Compatible Modules - Continued****5.5 B-507 Single Station Misfeed and Material Buckle Module**

The B-507 single station misfeed and material buckle combination module is used to provide both misfeed and material buckle protection in one convenient package. The LEDs located on the left of the unit pertain to the misfeed monitoring function while those to the right pertain to the material buckle monitoring function.

The following describes the functions of the B-507 module.

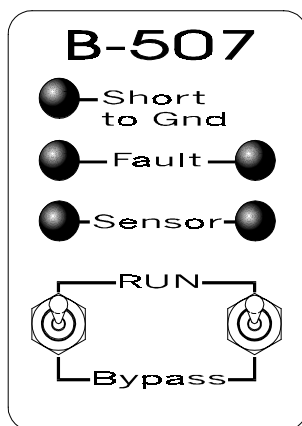

**Figure 5.5**  
**B-507 Module**

**Short to Gnd (Red LED):**

When active, a fault condition has occurred that indicates the misfeed sensor has made contact with the end of the material strip at the time the rotary cam switch re-opened. The press will stop if this condition is recognized. Short to Gnd is a "FAIL SAFE" circuit. The misfeed sensor must make contact with the material at the beginning of every press stroke.

**Fault (Red LED):**

If the *left* Fault LED is active, a misfeed condition has occurred. It is an indication that material stock is jammed in the die area and has failed to make contact with the misfeed sensor prior to initial closing of the rotary cam switch contacts. The press will stop during this condition. If the *right* Fault LED is active, a fault condition has occurred in the die area indicating that material has made contact with the sensor. The press will stop during this condition.

**Sensor (Green LED):**

The *left* Sensor LED is active anytime material makes contact with the misfeed sensor. The *right* Sensor LED is active anytime material makes contact with the material buckle sensor.

**RUN/Bypass (Toggle Switch):**

The *left* RUN/Bypass switch is used to disable the misfeed monitoring portion of the B-507 module. The *right* RUN/Bypass switch is used to disable the material buckle portion of the B-507 module. When either switch is in the Bypass position, the corresponding portion of the B-507 module will not stop the press even though a fault condition may exist. It is used to disable the functionality of that portion of the module. Placing the switch in the RUN position will allow the B-507 to monitor the proper die operation and stop the press during fault conditions.

## 6

**DMS – 302 Rotary CAM Timing**

After the installation of the DMS-302 has been completed, (sensor placement, cable routing, etc.), the CAM timing must be setup in order for the die monitoring system to correctly work. To begin this task, start jogging the press. The feeder should begin to load material in to the die area of the press as soon as possible. The feed process should be checked between 10 and 70 degrees of the press's crank angle.

Take notice of the point where the material has been completely fed in to the die area. At this point, the misfeed sensor should be making contact with the material. Also take notice of the point where the parts are ejected and pass through the light screen sensor (if used). The light screen should be placed as close as possible to the part ejection area so that part travel is minimized. Once these points have been determined, jog the press an additional 20 to 30 degrees, then set the rotary CAM switch to close its contacts at this position.

Continue to jog the press. Take notice that the rotary CAM switch contacts should re-open after the material loses contact with the misfeed sensor and before the next material feed begins (during bottom portion of the cycle). Continue to adjust the rotary CAM switch until the timing is correct.

The rotary CAM switch closing dwell time should *always* be between 150 and 180 degrees for proper operation of the DMS-302 die monitoring system.

**The timing set for the longest fed application will never have to be changed because it will meet the necessary timing for the applications that have shorter feeds.**

See the timing diagrams on the next page for details.

**Note:**

**Timing for the DMS-302 die monitoring system is accomplished through the use of one timing signal provided by the rotary CAM switch. All cyclic events will be checked at the closing point of the rotary CAM switch. If material feed has not made contact with the misfeed sensor, or the part has not been properly ejected, the press will be stopped at the closing of the rotary CAM switch. If contact between material and the misfeed sensor is made at the opening of the rotary CAM switch, the press will be stopped.**

6

**DMS – 302 Rotary CAM Timing - Continued**

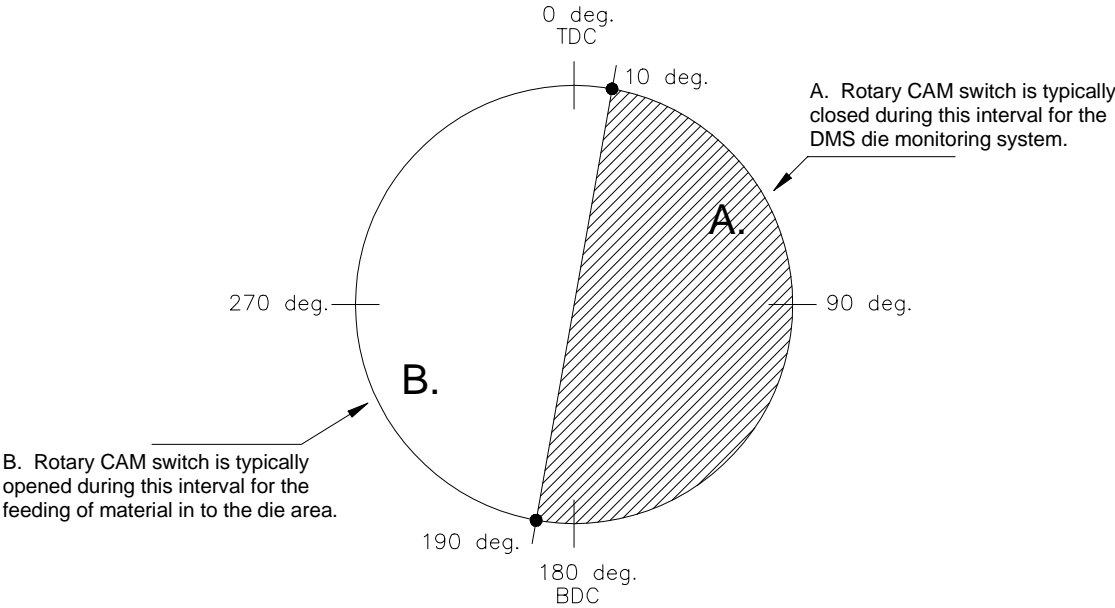

**Figure 6.1 Rotary CAM switch timing for the DMS-302**

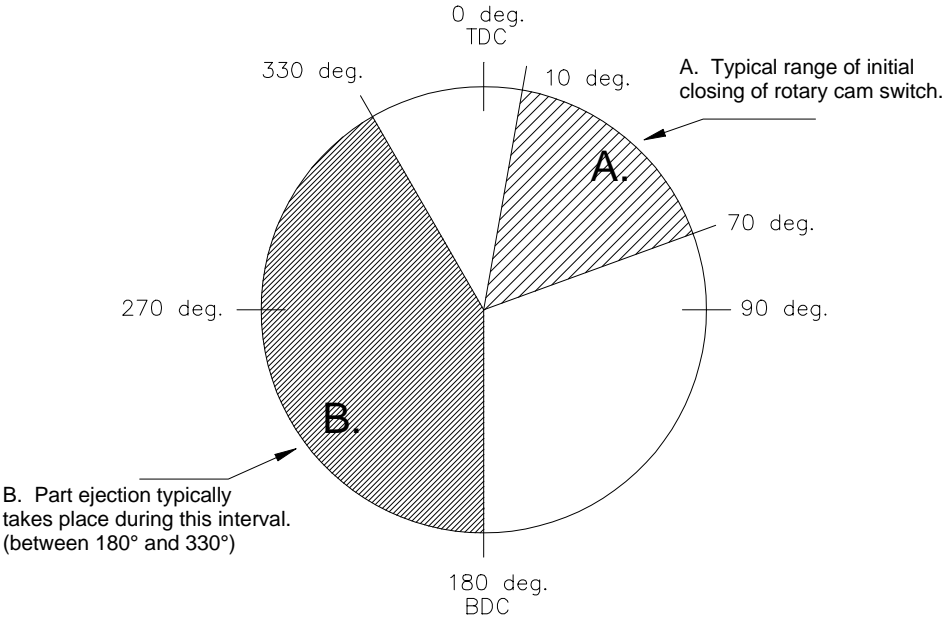

**Figure 6.2 Operating Sequence for Rotary CAM switch**

7

**DMS – 302 Mechanical Dimensions**

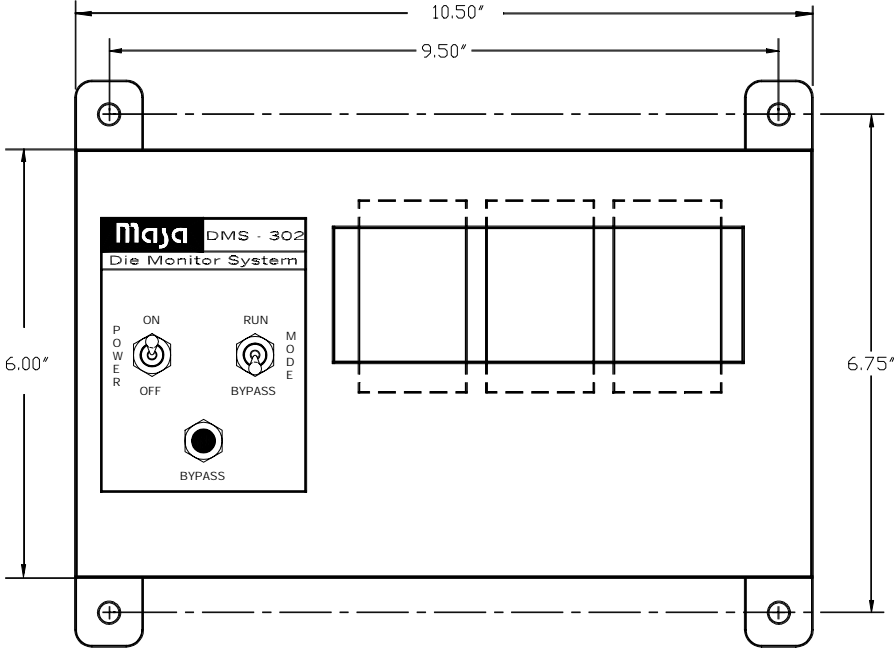

**Figure 7.1 DMS-302 Mechanical Dimensions**

8

**DMS – 302 Wiring Diagram**

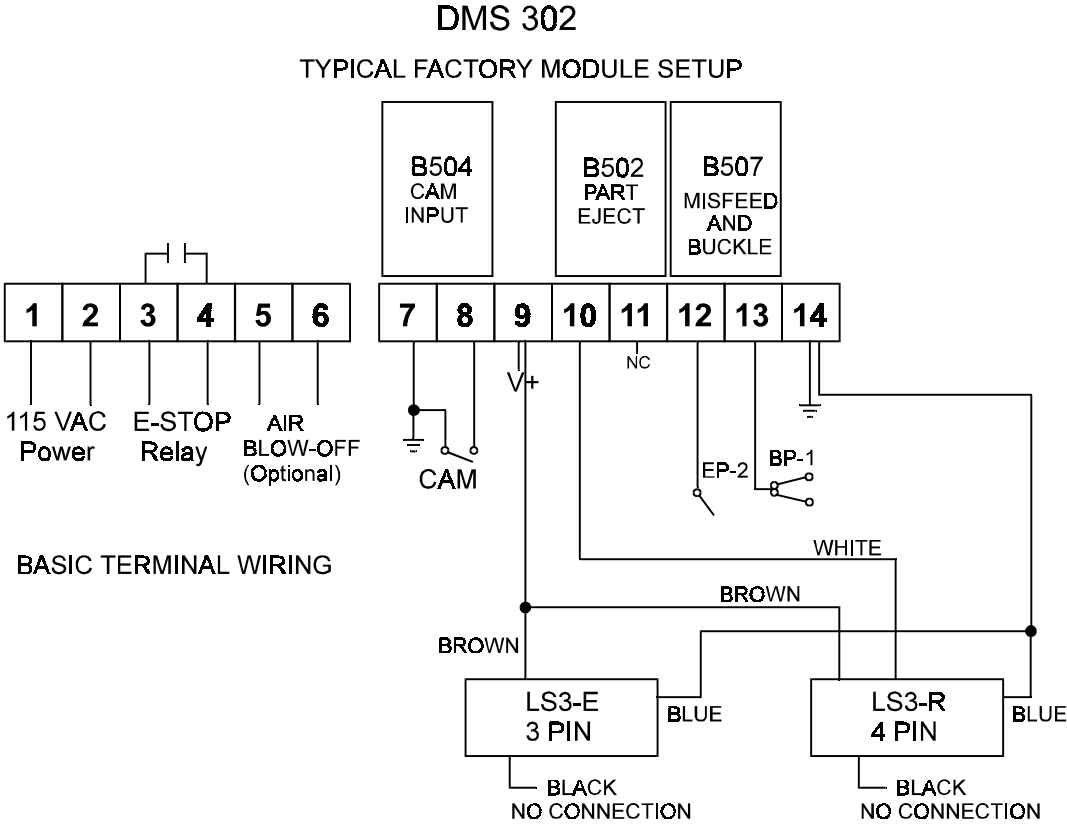

**Figure 8.1 DMS-302 Control Board Wiring Diagram**

**Notes:**

1. V+ denotes power supply to sensors (180mA MAX)
2. The terminal strip connections for single station modules is as follows:  
 TERMINAL #10 = Station 1  
 #12 = Station 2
3. The terminal strip connections for double station modules is as follows:  
 TERMINAL #10 = Station 1  
 #11 = Station 2  
 #12 = Station 3  
 #13 = Station 4